



CONTROLI

CONTROL SOLUTIONS FOR HVAC-R AND BUILDING AUTOMATION

VALVES & ACTUATORS 2021



Sensors & Controllers



DOWNLOAD OUR CATALOGUES IN PDF FROM OUR WEBSITE WWW.CONTROLLI.EU OR USE THESE QR CODES.



Valves & Actuators



SINCE 1936 A LEADING
COMPANY IN HVAC AND
BUILDING AUTOMATION



COMPANY PROFILE

CONTROLLI was established in Genoa in 1936 and was the first Italian company to manufacture a complete range of controllers, actuators and control valves for heating and air-conditioning systems.

Since 1950 the product range was improved by widening the range of control equipments and systems for industrial application.

In the 80s CONTROLLI consolidates its position as the most important Italian manufacturer, with special regard to climate controls, thanks to the development of analogue and digital electronic devices.

In the 90s CONTROLLI gains a position also in the Building Automation market.

From 1996 to July 2005 CONTROLLI has been part of the Invensys multinational group.

From 2005 to August 2011 CONTROLLI has been part of Schneider Electric S.A.

CONTROLLI is recognised today as an Italian leader in the Building Automation market and a benchmark in the segment of valves and actuators for the HVAC market.

Business with OEMs (Original Equipment Manufacturers) is more than 30% of our turnover. System integration for BMS is part of our business too. Our Building Automation team develops control software for free programmable controllers according to customers' specifications. Since several years we are mainly focusing on cutting-edge solutions aiming at guaranteeing the highest level of comfort but keeping a close eye on energy saving technologies. Some of these technologies refer to: heat metering systems, control devices with wireless communication, circuit balancing and more.

CORE BUSINESS

CONTROLLI core business consists of products and systems for the control and supervision of HVAC plants and industrial processes.

CONTROLLI products are the result of mechanical - electric - electronic technology integration, supported by a 80-years experience in HVAC applications.



* The port of Genoa



PRODUCT QUALITY IS CONTROLLI N°1 COMMITMENT

CONTROLLI operates under ISO9001-2008 Quality Certificate System. All CONTROLLI valves are PED (Pressure Equipment Directive) compliant. Products are tested 100%.

An industrial area of 6000 m² in Sant'Olcese (Genoa) is CONTROLLI head office. Production is highly automated with robotic devices for the assembly and calibration of mechanical and electronic spare parts and finished products.

It is worth mentioning the robotic plant for processing, mounting and testing of valve bodies and the robotized workcell for assembly, testing and certification of fan coil valve actuators.

CONTROLLI has adopted the SIX SIGMA procedures, further elevating the quality standard of its products.

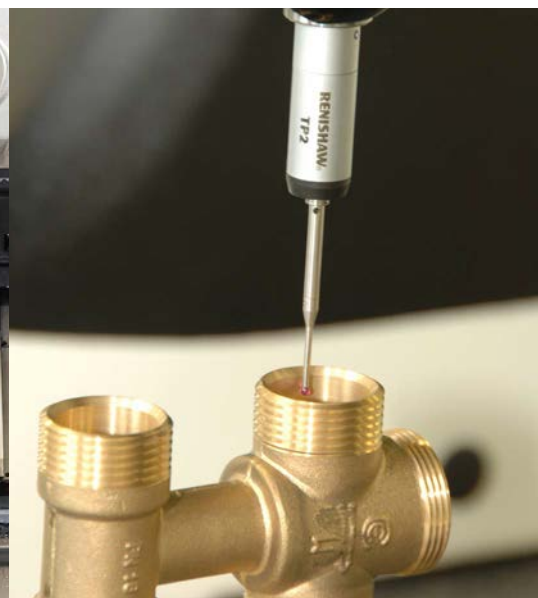
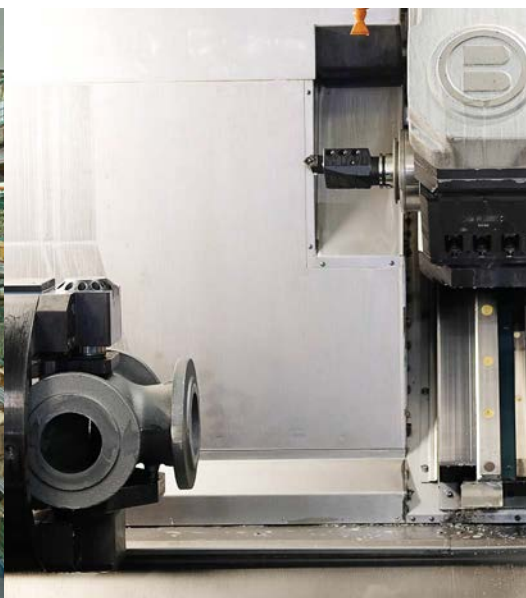

SALES ORGANIZATION

Sales & Marketing Dept. is in Sant'Olcese (Genoa).

Italian sales network consist of Sales-Offices in Milan, Genoa, Rome and Padova, 45 representatives and 75 authorised dealers throughout the Italian territory.

Abroad CONTROLLI operates through a widespread network of distributors and agents in Europe, Africa, Middle East, Far East, North and South America. By getting in touch with the nearest CONTROLLI sales point, the customers will find solution to any technical and commercial issue.

TECHNICAL SUPPORT

Our offices will provide a continuous technical assistance and support for systems and devices, application information, quotations and wiring diagrams.

Moreover, CONTROLLI holds periodically training courses for different levels of technical expertise and class of customers.

FIELDS OF APPLICATION

Offices



Hotels



Industrial plants



Data centers



Hospitals



Research centers



Universities



Swimming pools



Transports



Residential



Public offices



Shopping centers



WHERE TO FIND US

CONTROLLI

Controlli S.p.a.

Via Carlo Levi, 52

16010 Sant'Olcese

Genova - Italy

Controlli is located 10 Km north of Genova.

 take the A7 highway (genova-milano) and exit at Genova Bolzaneto.

 44.4862, 8.9223

 Closest Railway Station: Genova Piazza Principe

 **GENOA AIRPORT** ▶ **CONTROLLI**

 A7 Highway 16min
13.7Km

 **LINATE AIRPORT** ▶ **CONTROLLI**

 A7 Highway 1h e 13min
149Km

 **PISA AIRPORT** ▶ **CONTROLLI**

 A12 Highway + E80 1h e 35min
172Km

 **MALPENSA AIRPORT** ▶ **CONTROLLI**

 A7 Highway + E62 1h e 53min
181Km

 **BERGAMO AIRPORT** ▶ **CONTROLLI**

 A7+A4 Highway 2h e 2min
195Km

 **NICE AIRPORT** ▶ **CONTROLLI**

 A10 Highway + E80 2h e 5min
206Km

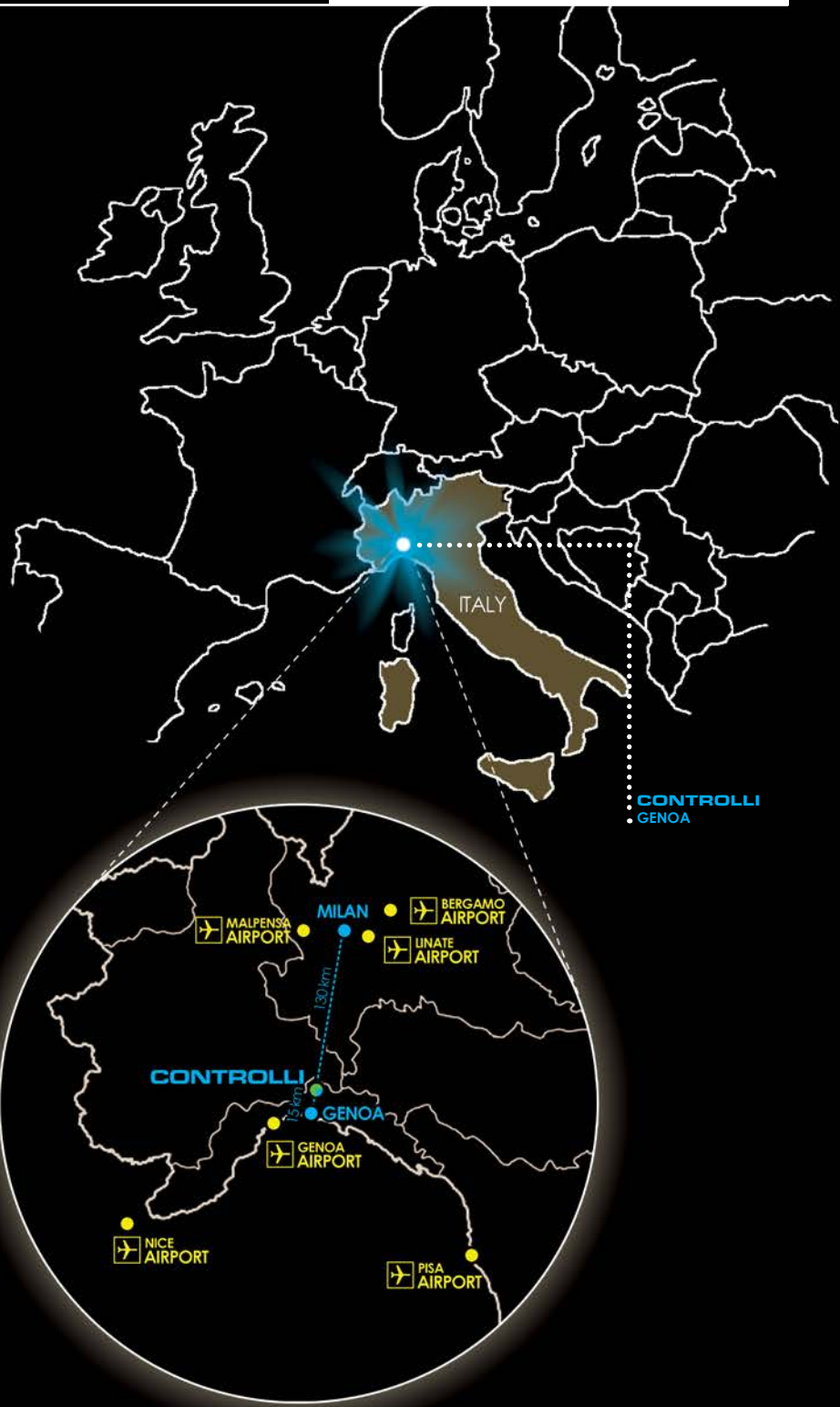

Controlli provides a series of resources to make it as easy as possible for you to identify the products you need.

DATA SHEETS	Specify manufacturing and technical characteristics of products and their application, installation, wiring connections and start-up instructions.
PRODUCT SELECTION GUIDE	Gives a brief description of Controlli product range according to different applications.
USERS' INSTRUCTIONS	Provide the information for the correct use of the equipment and for its maintenance.
BROCHURES	Advertise single Controlli products or control systems.
APPLICATION DIAGRAMS	Illustrate the most common applications, indicating the equipment of control system, basic system and wiring diagram.
PRICE LIST	Lists the prices and sales conditions.
CATALOGUE	Our product range catalogue is also available on Controlli website.
APPLICATION ENGINEERING OFFICE	Available for technical information, selection, application and quotations of equipment and complete control systems.
SALES SERVICE	Consisting of our technical staff and authorised assistants for technical support, commissioning, repairs and maintenance.
TECHNICAL TRAINING COURSES	Courses are held periodically for both technical and commercial staff on equipment and control systems. Moreover, there are courses aimed at the users of digital supervision systems.
WEB SITE	Check our total portfolio by visiting www.controlli.eu , which gives direct access to the latest version of all our data sheets.

WEBUP.CONTROLLI.EU

Our customers have free access to our WEBUP online service, where they can check the updated situation for any order, shipment, as well as download documents and invoices.

VALVE CONFIGURATOR

Web app for selecting the correct model and size of valve for: water, superheated water, steam, heat-transfer oil.

Selection of the correct size of valves is very important when designing energy-efficient HVAC plants. With Controlli Valve Sizer selection of globe control valves and matching actuators becomes easy and fast. This software is available from our web site.

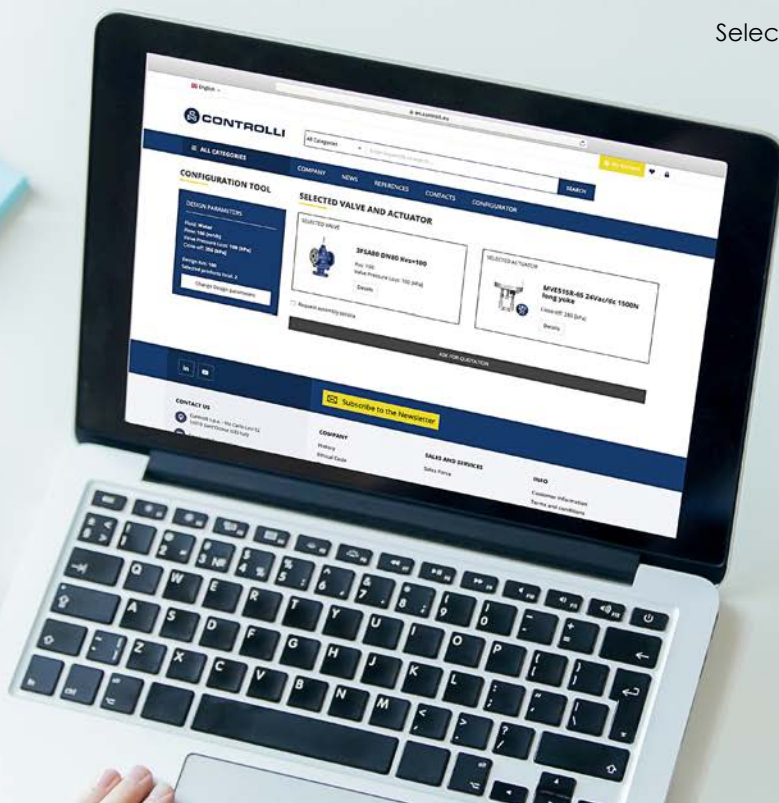



**VALVES
& ACTUATORS**

We are proud to offer one of the largest range of valves and actuators in the HVAC market. Valves range from 15mm to 200mm for fluids with temperature from -30°C to +350°C, max. pressure 12bar (steam) or 30bar (water). Linear actuators start at 90N and go up to 3000N. Rotary actuators for butterfly valves and shoes valves and for direct mounting on air dampers up to 2sqm.



CONTROLLERS

To start with, we will mention our thermostats for heating and cooling, our fan coil units controllers, room controllers, ddc controllers with parameter-setting as well as programmable controllers. Not to forget our KX climatic controllers with outside temperature compensation. Controllers are offered either as stand-alone or with Modbus connectivity. Our range includes sensors, transmitters and switches for temperature, humidity, pressure, differential pressure, air quality, etc.



**SUPERVISORY
SYSTEMS**

To make matters easy, we propose a brand new touch screen device with attractive graphics, multiple connectivity options and web gate capability. Remote monitoring also takes advantage of GTX703 our IoT gateway with HTML5 Web Browser. This device is compatible with the Industry 4.0 (Smart Factory).



ENERGY SAVING

CONTROLLI is offering an innovative Energy Saving solution based on IoT and Machine Learning Algorithm. "ENERBRAIN" is based on a unique technology reducing the energy consumption for the heating / cooling / ventilation systems by an average 30% in medium or large BMS installations. No need to replace the existing controllers! This system is extremely attractive to owners / contractors / real estate companies willing to achieve a significant reduction of the energy bill without replacing the existing BMS.

FOR CONTROL EQUIPMENT
PLEASE REFER TO OUR
CATALOGUE DEDICATED TO
"SENSORS & CONTROLLERS"





MICRA® MOTORIZED VALVES FOR FCUs

Brass valves for FCUs 2way, 3way, 3way + bypass, Kvs 0,25 to 6, with On-Off / Modulating thermic actuators (140N force) and 3 pos. / Modulating electric actuators (300N force).



GLOBE VALVES WITH THREADED CONNECTIONS

Cast iron or bronze PN16 valve bodies with threaded connections 1/2" up to 2" for fluids from -10 °C to +150 °C.



GLOBE VALVES WITH FLANGED CONNECTIONS

PN16, PN25, PN40 globe valves with flanged connections DN15mm to DN200mm, suitable for fluids (water, glycol, steam, thermal oil) from -30 °C to +350 °C.



GLOBE VALVE ACTUATORS

Linear actuators from 300N to 3000N, with or without spring return. Includes MVE range of new generation actuators 400N, 600N, 1000N, 1500N & 2200N force with self adjusting and auto diagnostic capabilities.



BUTTERFLY VALVES

PN16 butterfly valves, 100% tight close-off, DN25mm to DN200mm to be motorized by MDL or MDA actuators (up to 40Nm).



PICVs

PN16 / PN25 dynamic pressure independent control valves 1/2" to 2" and DN65 to DN125 with On/Off or proportional actuators suitable to fluids up to 120 °C.



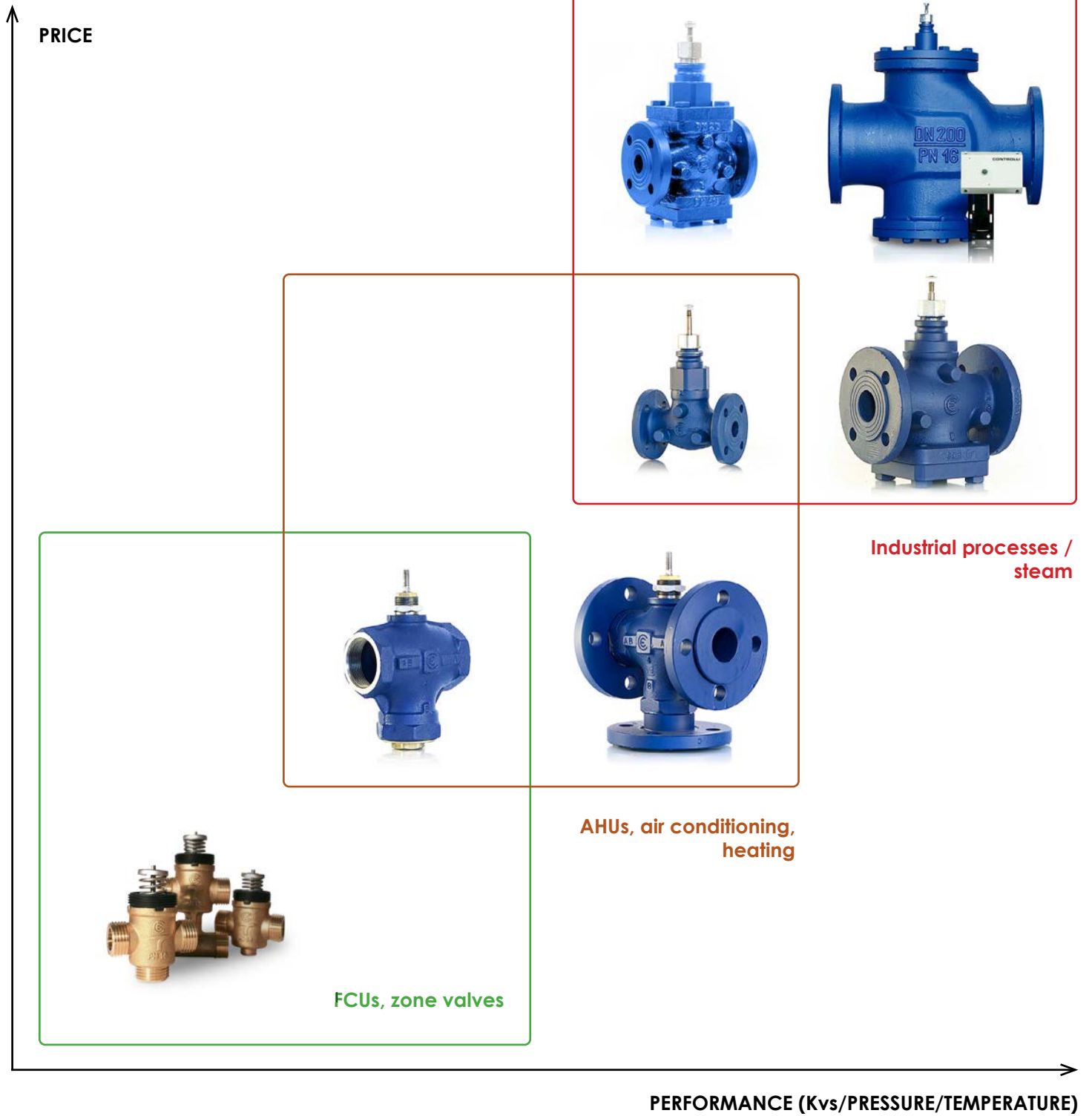

PRICE

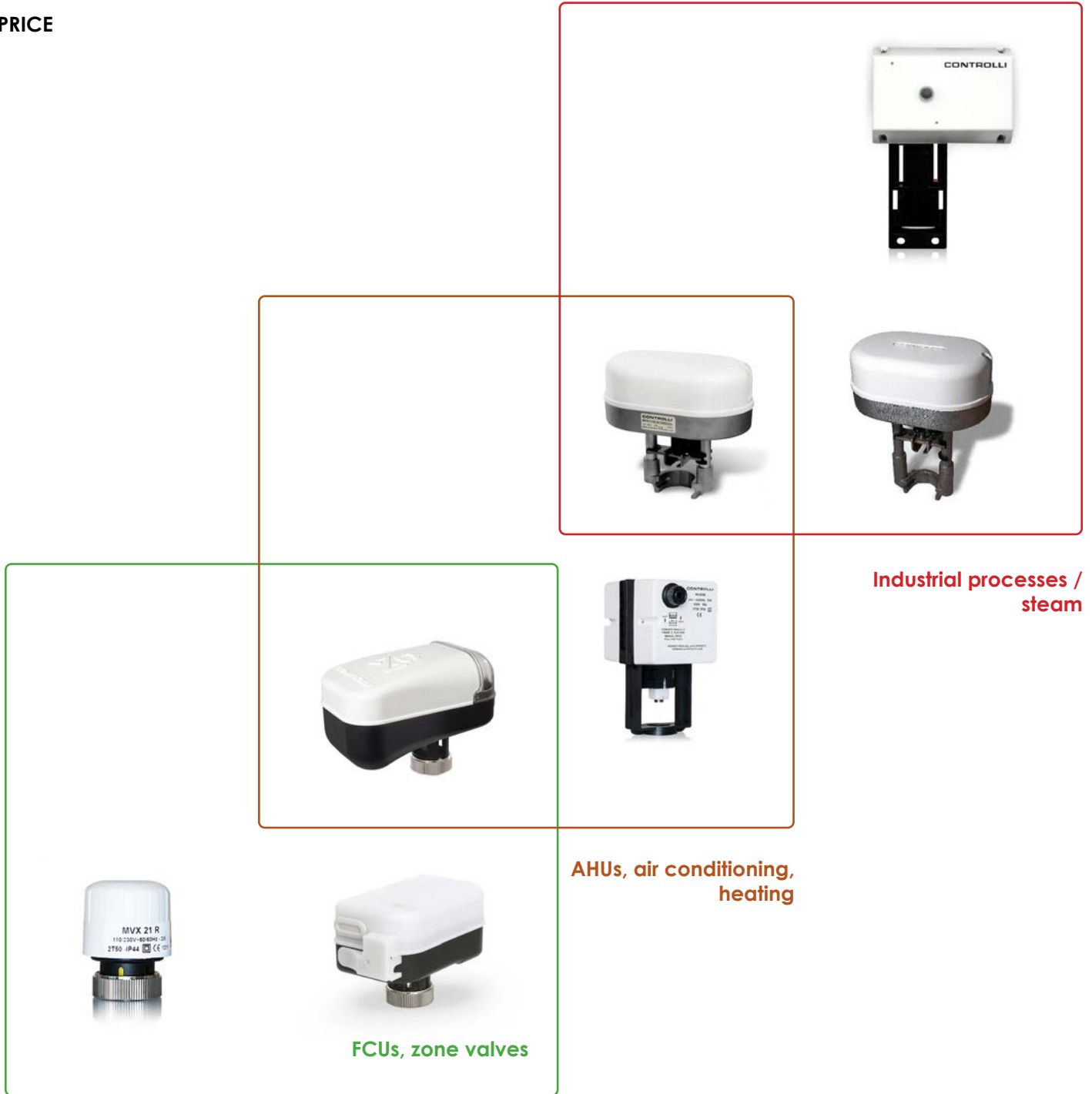

Industrial processes / steam

AHUs, air conditioning, heating

FCUs, zone valves

90N-140N

300N

600N

3000N

FORCE

450N

1500N

VALVE LINKING KIT FOR FCUs **NEW**

CODE	DESCRIPTION	
BP40-15	By-pass with 1/2" threaded connections (strainer included) 2-way	
BP40-20	By-pass with 3/4" threaded connections (strainer included) 2-way	
BP80-25	By-pass with 1" threaded connections (strainer included) 2-way	
BP43-15	By-pass with 1/2" threaded connections (strainer included) 3-way	
BP43-20	By-pass with 3/4" threaded connections (strainer included) 3-way	
BP83-25	By-pass with 1" threaded connections (strainer included) 3-way	
ACCESSORIES	Flex15	1/2" stainless-steel flexible hose; 200mm (max. extended length)
	Flex20	3/4" stainless-steel flexible hose; 200mm (max. extended length)
	Flex25	1" stainless-steel flexible hose; 200mm (max. extended length)
	Flex15L	1/2" stainless-steel flexible hose; 400mm (max. extended length)
	Flex20L	3/4" stainless-steel flexible hose; 400mm (max. extended length)
	Flex25L	1" stainless-steel flexible hose; 400mm (max. extended length)
	KITAV2	Labour (assembling and testing, kit with 2-way valve or PICV)
	KITAV3	Labour (assembling and testing, kit with 3-way valve)
	COIB	Thermal insulation of the whole kit



APPLICATION AND USE

Controlli valve linking kits are designed to connect a fan coil unit directly into a building's chilled water or hot water network.

Each kit includes an inbuilt factory-assembled set of valves and accessories in order to reduce on site installation and commissioning times and to prevent potential future system leakage from fan coil unit systems. It may also include a balancing valve with pressure tests points, installed on the return line.

All necessary components are installed as a single item which is then 100% pressure-tested in the factory prior to delivery to site.

No specific tools are needed for installation. A built-in bypass section includes a full port isolating valve to enable coil and circuit flushing and cleaning to be carried out without the need to switch off the attached fan coil unit.

Thermal insulation can be added too.

All products are manufactured, assembled and tested in Italy.

TECHNICAL CHARACTERISTICS

Material: DZR brass
 Pressure class: PN16 (flexible hoses are PN10)
 Fluid temperature range: 0°C to 120°C

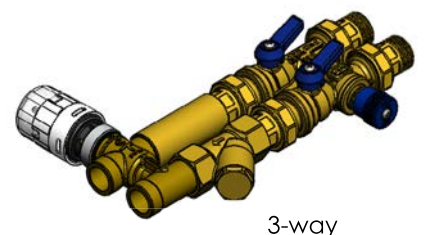
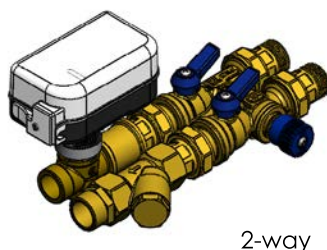
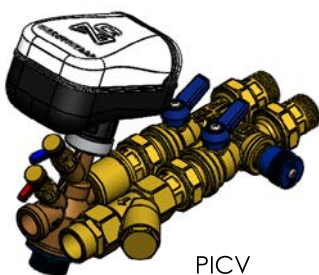
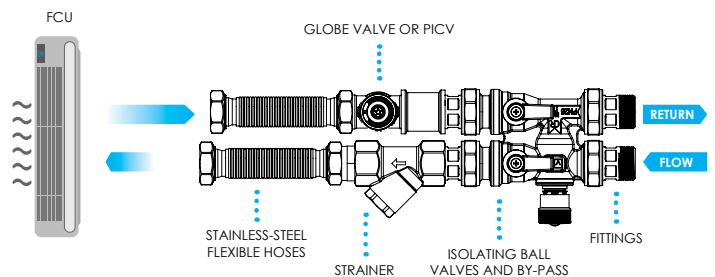

Creating a valve linking kit is as easy as 1 2 3

1 SELECT YOUR BYPASS

To make it easy, we have reduced the range to three models only, all including a flow limitation and isolation valves to allow different directions of the water as needed during the normal operation of the terminal unit as well as flushing, cleaning or isolation for maintenance operations. Compact design suitable also for installations with limited space.



2 SELECT YOUR VALVE AND ACTUATOR

Valve type and size need to be selected according to the circuit specifications and nominal flow rates.

You can choose between a variety of types (2way globe valve, 3way mixing globe valve, PICV with or without P/T plugs, 2way ball valve, 3way mixing or diverting ball valve) and sizes (1/2", 3/4", 1"). We always recommend selecting a globe valve using the Kvs value (flow rate and pressure drop) and a PICV using the nominal flow rate.



3 CHOOSE YOUR OPTIONS

We can fit stainless-steel hoses with different length in order to match closely your FCU dimensions. Having all parts already assembled in our factory will save a lot of installation time on site. See below what accessories are available. Other options and variants are available on demand.



CODE	DIMENSION "A"	THREADED CONNECTIONS f1, f2, p1, p2
BP40-15	40 mm	1/2"
BP43-15	40 mm	1/2"
BP40-20	40 mm	3/4"
BP43-20	40 mm	3/4"
BP80-25	80 mm	1"
BP83-25	80 mm	1"

TYPE	VALVE MODEL		Kvs	ACTUATOR SERIES	
	VSX09P ÷ VSX13P	VLT1P		VSX21P or VSX24P	VSX26P
2-way globe valve	VSX09P ÷ VSX13P	VLT1P	0,25 ÷ 1,6 m³/h	VSX21P or VSX24P	VSX (Thermal)
	VSX09P ÷ VSX13P	VLT2P	0,25 ÷ 1,6 m³/h	VSX21P or VSX24P	MVT/MVC (Electro-mechanical)
PICV	VLT1P	VLT2P	100 ÷ 375 l/h	VLT1P	MCA/MVR (Thermal)
	VLT1P	VLT2P	160 ÷ 800 l/h	VLT1P	MVT/MVC (Electro-mechanical)
3-way globe valve	VTX09P ÷ VTX13P	VTX09P ÷ VTX13P	0,25 ÷ 1,6 m³/h	VTX09P ÷ VTX13P	MVT/MVC (Electro-mechanical)
	VTX09P ÷ VTX13P	VTX09P ÷ VTX13P	0,25 ÷ 1,6 m³/h	VTX09P ÷ VTX13P	MVT/MVC (Electro-mechanical)
2-way globe valve	VSX21P or VSX24P	VSX21P or VSX24P	2,5 ÷ 4 m³/h	VSX21P or VSX24P	MVT/MVC (Electro-mechanical)
	VSX21P or VSX24P	VSX21P or VSX24P	2,5 ÷ 4 m³/h	VSX21P or VSX24P	MVT/MVC (Electro-mechanical)
PICV	VLT2P	VLT3P	160 ÷ 800 l/h	VLT2P	MCA/MVR (Thermal)
	VLT2P	VLT3P	200 ÷ 1000 l/h	VLT2P	MVT/MVC (Electro-mechanical)
3-way globe valve	VTX21P4	VTX21P4	2,5 m³/h	VTX21P4	MVT/MVC (Electro-mechanical)
	VTX21P4	VTX21P4	2,5 m³/h	VTX21P4	MVT/MVC (Electro-mechanical)
2-way globe valve	VSX26P	VSX26P	6 m³/h	VSX26P	MVT/MVC (Electro-mechanical)
	VSX26P	VSX26P	6 m³/h	VSX26P	MVT/MVC (Electro-mechanical)
PICV	VLT3P	VLT4P	200 ÷ 1000 l/h	VLT3P	MCA/MVR (Thermal)
	VLT3P	VLT4P	400 ÷ 2000 l/h	VLT3P	MVT/MVC (Electro-mechanical)
3-way globe valve	VMX24P or VMX26P	VMX24P or VMX26P	4 ÷ 6 m³/h	VMX24P or VMX26P	MVT/MVC (Electro-mechanical)
	VMX24P or VMX26P	VMX24P or VMX26P	4 ÷ 6 m³/h	VMX24P or VMX26P	MVT/MVC (Electro-mechanical)

FLEXIBLE HOSES	ASSEMBLING AND TESTING	THERMAL INSULATION
Flex15 or Flex15L		
Flex20 or Flex20L	KITAV2 (2-way) or KITAV3 (3-way)	COIB
Flex25 or Flex25L		



MICRA®

Motorized valves with compact dimensions for FCUs

Micra® is our successful range of motorized valves for fan coil units. Range consists of PN16 brass (CW617N) valve bodies with compact dimensions: 2way, 3way, 3way-4ports. With sizes 1/2" and 3/4" and Kvs from 0,25 to 6. Valves are 100% tight close-off.

All valve bodies are available with either flat end threaded connections or conic (Conex). 4-ports versions (3way with bypass) are available with different port-to-port distances (C)

- | | |
|---------------------------------|-------------------------|
| 1/2" models with Kvs up to 1,6: | 35 mm or 40 mm distance |
| 3/4" models with Kvs up to 2,5: | 40 mm or 50 mm distance |
| 3/4" models with Kvs up to 6: | 44 mm distance |

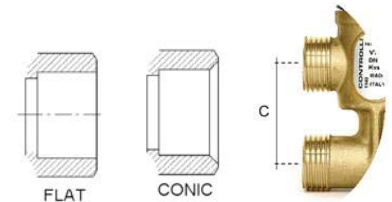

VSX (2-way), VMX (3-way), VTX (3-way 4-ports)

- Valves with 2,5 mm stroke
- For electro-thermal actuators (On/Off or modulating)
- Totally silent
- Spring return (Normally Open & Normally Closed depending on actuator models)
- No friction, no wear
- Price competitive solution

VSXT (2-way), VMXT (3-way), VTXT (3-way 4-ports)

- Valves with 5,5 mm stroke
- For electro-mechanical actuators
- Faster opening / closing times
- Higher close-off
- Better modulating control
- 3 pos. control also available

Actuators series **MXV 140 N** Electrothermal actuator for V.X valves with Kvs from 0,25 to 6
Stroke end indicator - 2 m. bipolar/tripolar cable - Protection IP44.

MODEL	STARTING TIME [s]	POWER SUPPLY [Vac]	FORCE [N]	ACTION
MVX22R	90	110-230	140	on-off
MVX42R	90	24	140	on-off, PWM
MVX52	90	24	140	proportional 0-10 Vdc



Valve Bodies with **2.5 mm stroke** for fan coil units: Kvs 0.25 ÷ 2.5

Series **V.X.** - **PN16** brass valve bodies - Tight close-off both on direct and angle way - PPS plug with double EPDM o-ring - Fluid: water and water+glycol 30% max. - Temperature 5÷95°C
Stroke 2.5 mm - Threaded connections for conic and flat tight - Motorised by MVX and MVR.V.

MODEL	Kvs		CLOSE OFF [bar]	ACTION TYPE ON DIRECT WAY	THREADED CONNECTIONS	TIGHT
	DIRECT WAY	ANGLE WAY				
VSX09P	0,25	-	4	2-way n.c.	G 1/2" M	flat
VSX10P	0,4	-	4		G 1/2" M	flat
VSX11P	0,6	-	4		G 1/2" M	flat
VSX12P	1	-	3,5		G 1/2" M	flat
VSX13	1,6	-	3,5		G 1/2" M	conic
VSX13P	1,6	-	3,5		G 1/2" M	flat
VSX21	2,5	-	3,5		G 3/4" M	conic
VSX21P	2,5	-	3,5		G 3/4" M	flat
VMX09P	0,25	0,25	4	3-way	G 1/2" M	flat
VMX10P	0,4	0,4	4		G 1/2" M	flat
VMX11P	0,6	0,6	4		G 1/2" M	flat
VMX12P	1	0,6	3,5		G 1/2" M	flat
VMX13	1,6	1	3,5		G 1/2" M	conic
VMX13P	1,6	1	3,5		G 1/2" M	flat
VMX21	2,5	1,6	3,5		G 3/4" M	conic
VMX21P	2,5	1,6	3,5		G 3/4" M	flat
VTX09P ¹⁾	0,25	0,25	4	3-way 4-ports	G 1/2" M	flat
VTX10P ¹⁾	0,4	0,4	4		G 1/2" M	flat
VTX11P ¹⁾	0,6	0,6	4		G 1/2" M	flat
VTX12P ¹⁾	1	0,6	3,5		G 1/2" M	flat
VTX13	1,6	1	3,5		G 1/2" M	conic
VTX13P ¹⁾	1,6	1	3,5		G 1/2" M	flat
VTX21	2,5	1,6	3,5		G 3/4" M	conic
VTX21P ¹⁾	2,5	1,6	3,5		G 3/4" M	flat



1) These models are also available with 40mm port-to-port distance (C). When ordering 40mm distance version, add "4" at the end of the model code e.g. VTX21P4. See also picture on pag. 14

Valve Bodies with 2.5 mm stroke for fan coil units: Kvs 4 and 6

Series **V.X.** - **PN16** brass valve bodies - Tight close-off both on direct and angle way - Brass plug with double EPDM o-ring Fluid: water and water + glycol 30% max. - Temperature 5 to 95°C - **Stroke 2.5 mm** - Flat threaded connection for conic and flat tight. Motorised by MVX actuators.

MODEL	Kvs		CLOSE OFF [bar]	ACTION TYPE ON DIRECT WAY	THREADED CONNECTIONS	TIGHT
	DIRECT WAY	ANGLE WAY				
VSX24P	4	-	1,5	2-way n.c	G 3/4" M	flat
VSX26P	6	-	1,5		G 3/4" M	flat
VMX24P	4	2,5	1 (0,4) ¹⁾	3-way	G 3/4" M	flat
VMX26P	6	4	1 (0,4) ¹⁾		G 3/4" M	flat
VTX24P	4	2,5	1 (0,4) ¹⁾	3-way 4-port	G 3/4" M	flat
VTX26P	6	4	1 (0,4) ¹⁾		G 3/4" M	flat

1) The values in brackets refer to the angle way.



Accessories

CODE	DESCRIPTION
VXC	Manual control for V.X and V.XT series valves
Thermal insulation, see page 42	

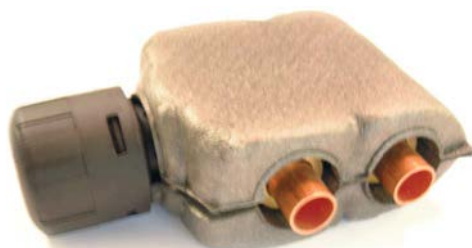

Valve Bodies with 5,5 mm stroke for fan coil units

For MVT and MVC actuators (page 36-37)

Series **V.XT** - **PN16** forged brass valve body - Tight close-off both on direct and angle way
 - Plug with double EPDM OR - Fluid: water and water+glycol 30% max., temperature 2 to 95°C - **Stroke 5.5 mm** - Flow characteristic: equal-percentage direct way, linear angle way. To be motorised with MVT actuator and MVC503R.

MODEL ¹⁾	Kvs		CLOSE OFF [bar]	ACTION TYPE DIRECT WAY	THREADED CONNECTIONS	TIGHT
	DIRECT WAY	ANGLE WAY				
VSXT09P	0,25	-	4	2-way n.c	G 1/2" M	flat
VSXT10P	0,4	-	4		G 1/2" M	flat
VSXT11P	0,6	-	3,5		G 1/2" M	flat
VSXT12P	1	-	3,5		G 1/2" M	flat
VSXT13P	1,6	-	3,5		G 1/2" M	flat
VSXT1P	2	-	3,5		G 1/2" M	flat
VSXT21P	2,5	-	3,5		G 3/4" M	flat
VSXT24P	4	-	1,5		G 3/4" M	flat
VSXT26P	6	-	1,5		G 3/4" M	flat
VMXT09P	0,25	0,25	4	3-way	G 1/2" M	flat
VMXT10P	0,4	0,25	4		G 1/2" M	flat
VMXT11P	0,6	0,4	3,5		G 1/2" M	flat
VMXT12P	1	0,6	3,5		G 1/2" M	flat
VMXT13P	1,6	1	3,5		G 1/2" M	flat
VMXT1P	2	1,6	3,5		G 1/2" M	flat
VMXT21P	2,5	1,6	3,5		G 3/4" M	flat
VMXT24P	4	2,5	1 (0,4) ¹⁾		G 3/4" M	flat
VMXT26P	6	4	1 (0,4) ¹⁾		G 3/4" M	flat
VTXT09P ²⁾	0,25	0,25	4	3-way 4-ports	G 1/2" M	flat
VTXT10P ²⁾	0,4	0,25	4		G 1/2" M	flat
VTXT11P ²⁾	0,6	0,4	3,5		G 1/2" M	flat
VTXT12P ²⁾	1	0,6	3,5		G 1/2" M	flat
VTXT13P ²⁾	1,6	1	3,5		G 1/2" M	flat
VTXT1P ²⁾	2	1,6	3,5		G 1/2" M	flat
VTXT21P ²⁾	2,5	1,6	3,5		G 3/4" M	flat
VTXT24P	4	2,5	1 (0,4) ¹⁾		G 3/4" M	flat
VTXT26P	6	4	1 (0,4) ¹⁾		G 3/4" M	flat

All V.XT valves are available with conic connection. When ordering this version, ignore the letter "P" at the end of the model code; e.g. VSXT21.

1) The values in brackets refer to the angle way.

2) These models are also available with 40mm port-to-port distance (C). When ordering 40mm distance version, add "4" at the end of the model code e.g. VTXT21P4. See also picture on pag. 14





By a simple rotation of the actuator cover the installer can adjust it to manifolds or valves without the need of adapters (that are usually and easily lost).

MCA

Valve Adaptive concept without adapters

Protection from condensation and from leaking regardless of the valve position (throughout 360°)

Function Indicator Pin visible from any direction.

Fast installation thanks to our Manual Override Position.

MCA has not only a protection from condensation and from water leak whichever is the mounting position (IP54 also up side down), but it is designed to be adapted to the majority of underfloor heating manifolds and zone valves up to 4 mm stroke available on the market without the need of any

adapters. Another peculiarity of MCA is the Manual Override position, which allows opening and closing the valve/manifold through an easy operation and without powering the actuator.

Last but not least, the MCA is equipped with an ON/OFF Position Indicator, visible from any directions, which allows an easy and fast installation.

As for any other Controlli product, the reliability and quality are key requirements, that's why our products continuously undergo life tests and each MCA is tested before being

shipped to the customer.

MCA is available with or without a end-stroke switch contact and with the possibility to be powered with 110/220 Vac or 24 Vac/dc.

MCA is then the ideal product for installers and distributors who can use it on any manifolds/valves but also for OEMs thanks to its high performances, its installation quickness as well as the possibility to be customized for example with the customer's logo.

MODEL	POWER SUPPLY [Vac]	AUXILIARY MICROSWITCH	FORCE [N]	STROKE [mm]	PROTECTION
MCA230L	110+230	--	140	4	IP54
MCA230LM		•			
MCA24L	24	--			
MCA24LM		•			

MVR

Electrothermal actuator **140 N** for manifolds, radiant panels and PICVs

On/off and PWM control - Fast opening/closing times - 24 Vac/dc, 110-230 Vac, 50-60 Hz - IP44 - 4,0 mm stroke - M30x1,5 connection on valves/manifolds - 140 N force Starting time 60 sec. Auxiliary microswitch. Operation MVR (not MVR.V): without power supply MVR spindle is in "outside" position; when powered MVR pulls the spindle "inside". All models are also available with auxiliary microswitch; when ordering this version, add the letter "M" to the model code, e.g. MVR230MC2 or MVR24MV.



MODEL	STEM OUTPUT	POWER SUPPLY	FORCE [N]	ACTION
MVR230	10,7÷11,8	110-230 Vac	140	on-off
MVR24	10,7÷11,8	24 Vac/dc	140	on-off, PWM
MVR230V	Compatible with MICRA valves	110-230 Vac	140	on-off
MVR24V		24 Vac/dc	140	on-off, PWM
MVR230C1 ¹⁾	12,3÷13,4	110-230 Vac	140	on-off
MVR24C1 ¹⁾	12,3÷13,4	24 Vac/dc	140	on-off, PWM
MVR230C2 ¹⁾	11,3÷12,4	110-230 Vac	140	on-off
MVR24C2 ¹⁾	11,3÷12,4	24 Vac/dc	140	on-off, PWM
MVR230C3 ¹⁾	10,3÷11,4	110-230 Vac	140	on-off
MVR24C3 ¹⁾	10,3÷11,4	24 Vac/dc	140	on-off, PWM

¹⁾ Models suitable to manifolds or valves of many different brands. Please check Controlli "MVR_DBL310e" data sheet for details.

Customizable

Thanks to a little plastic stem adapter, our MVR thermal actuators are suitable to a number of different valves or manifolds.

Connection is M30x1,5. All materials are self-extinguishing rated V0. An indicator shows the open/closed position of the actuator.



MVX52B

Electro-thermal actuator **140 N** for MICRA valves and PICVs (pressure independent control valves)

MVX52B is a proportional 0..10 Vdc actuator suitable to a variety of applications:

- normally closed on pressure independent control valves;
- normally open on Controlli Micra® valves (VSX, VMX, VTX)
- normally closed on manifolds.

The actuator-valve assembly is easily achieved thanks to the M30x1,5 threaded ring nut. Actuator has a 4 mm fixed stroke and provides a proportional reverse action with 0-10 Vdc control signal.

The actuator is equipped with a potentiometer which allows to limit the valve maximum opening stroke (selectable from 20% to 100%).

When power is OFF: actuator spindle is completely inside.

When power is ON and control signal is 0 Vdc: actuator spindle is completely out (bottom position if mounting is vertical);

When power is ON and control signal is 10 Vdc: actuator spindle is completely inside (top position if mounting is vertical).

For example, if the potentiometer is set to 6 (60%):

- maximum stroke becomes 2,4 mm
- with 0 Vdc signal actuator spindle is in the bottom position and with 10 Vdc signal actuator reaches 60% of the whole stroke (2,4 mm).

Micra® valves closure is guaranteed only by selecting 100%

More features: 24 Vac power supply at 50/60 Hz; 2 m cable triple-pole (0,35 mm²); IP44 protection; 140 N force; 4 mm stroke.

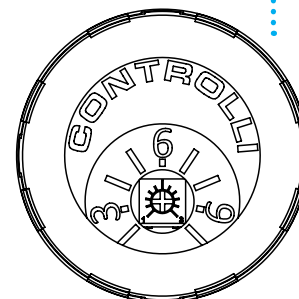

MORE OPTIONS

For all our electro-thermal actuators MVX, MCA, MVR and for all our electro-mechanical actuators MVT, MVC standard ring nut is M30x1,5 (for assembling the actuator onto the valves). M28x1,5 is available as a variant by adding **PS107** at the end of the actuator part-number.

For example:

MCA230L - standard version with M30x1,5 ring nut
MCA230LPS107 - special version with M28x1,5 ring nut

MVC403S - standard version with M30x1,5 ring nut
MVC403SPS107 - special version with M28x1,5 ring nut

Series **2T** (threaded) - **PN16** - Stroke 11,5 mm. To be motorised by MVB (2TGB.B) or MVE.S (2TGB.F) actuators.

MODEL	DN	Kvs	MAX DIFFERENTIAL PRESSURE [bar]	OTHER FEATURES
2TGB15BR00	1/2"	0,4	13,7	<ul style="list-style-type: none"> GJL-250 cast-iron body Brass internal parts Equal-percentage control flow characteristic Leakage 0 to 0,001% Kvs Female threaded connections: fluid temp. -5^o to 140 °C, with MVB max 120°C (140 °C with MVB+MVBHT) For MVB actuator For MVT203,403,503 actuators using AG74-03 adapter
2TGB15BR0	1/2"	0,63		
2TGB15BR1	1/2"	1		
2TGB15BR2	1/2"	1,6		
2TGB15BR3	1/2"	2,5		
2TGB15B	1/2"	4		
2TGB15FR00	1/2"	0,4	16	<ul style="list-style-type: none"> GJL-250 cast-iron body Brass internal parts Equal-percentage control flow characteristic Leakage 0 to 0,001% Kvs Female threaded connections: fluid temp. -5^o to 140 °C For MVE.S actuator
2TGB15FR0	1/2"	0,63		
2TGB15FR1	1/2"	1		
2TGB15FR2	1/2"	1,6		
2TGB15FR3	1/2"	2,5		
2TGB15F	1/2"	4		

In order to avoid seat & plug wearing issues we recommend not to exceed 4 bar differential pressure.
 3) For applications with ice formation on stem and packing, use the stem heater.



Series **VSB** (threaded) - **VSB.F** (flanged) - **PN16** - Stroke 16,5 mm. To be motorised by MVB - MVE - MVH actuators - Thermal insulation available.

MOD.	DN	Kvs	MAX DIFFERENTIAL PRESSURE [bar]							OTHER FEATURES
			MVB	MVE506	MVE510	MVE515	MVH	MVH56EA MVH56EC	MVE522	
VSB3	3/4"	6,3	10,8	16	16	16	16	16	16	<ul style="list-style-type: none"> G 25 cast-iron body Brass internal parts Female threaded connections: fluid temperature -10^o to 150 °C, with MVB max 120°C (140°C with MVB+MVBHT) Equal-percentage control flow characteristic Leakage 0,03% Kvs For MVE actuator, add AG52 linkage For MVH actuator, add AG62 linkage
VSB4	1"	10	6,8	11,9	16	16	16	13,8	16	
VSB5	1 1/4"	16	4,1	7,2	12,1	16	16	8,4	16	
VSB6	1 1/2"	22	2,9	5	8,6	13	11,7	5,9	16	
VSB8	2"	30	2,1	3,7	6,4	9,6	8,7	4,4	14,3	
VSB8A	2"	40	2,1	3,7	6,4	9,6	8,7	4,4	14,3	
VSB3F	20	6,3	10,8	16	16	16	16	16	16	<ul style="list-style-type: none"> As above but with slip-on flanges
VSB4F	25	10	6,8	11,9	16	16	16	13,8	16	
VSB5F	32	16	4,1	7,2	12,1	16	16	8,4	16	
VSB6F	40	22	2,9	5	8,6	13	11,7	5,9	16	
VSB8F	50	30	2,1	3,7	6,4	9,6	8,7	4,4	14,3	
VSB8AF	50	40	2,1	3,7	6,4	9,6	8,7	4,4	14,3	

By spring return MVHEA closed, MVHEC open.
 In order to avoid seat & plug wearing issues we recommend not to exceed 2 bar differential pressure.
 1) For applications with ice formation on stem and packing, use the stem heater.



VSB/VMB valves with male threaded connections "PS150"

Tight Close-off

Series **VSBP.M** threaded valves - Modulating tight close-off valves **PN16** - Stroke 16,5 mm. Thermal insulation available - To be motorised by MVB actuators.

MODEL	DN	Kvs	MAX DIFFERENTIAL PRESSURE [bar]	OTHER FEATURES
VSBP3M	3/4"	6,3	2 (8,8)	<ul style="list-style-type: none"> • G 25 cast-iron body • Fluid temperature -5 to 95°C • Leakage 0% Kvs
VSBP4M	1"	10	2 (5,5)	
VSBP5M	1 1/4"	16	2 (5,5)	
VSBP6M	1 1/2"	25	2 (2,5)	
VSBP8M	2"	36	1,8	

Values in brackets are max close-off differential pressure. In applications with steam, the value in brackets is not applicable. In order to avoid seat & plug wearing issues we recommend not to exceed 2 bar differential pressure.



Series **VSB.T** in G25 cast-iron **PN16** - Stroke 5,5mm - To be motorised by MVC.03 and MVC503R actuators.

MODEL	DN	Kvs	MAX DIFF. PRESSURE [bar]	OTHER FEATURES
		A-AB	A-AB	
VSB3T	3/4"	6,3	9	<ul style="list-style-type: none"> • G25 cast iron body • Fluid temperature 5 to 95 °C • Linear control characteristic • Leakage: direct way <0.03% Kvs, angle way < 2% Kvs
VSB4T	1"	10	5,5	
VSB5T	1-1/4"	14	3,5	
VSB6T	1 1/2"	18	2,5	
VSB8T	2"	25	1,9	

Old VSBT3, VSBT4, VSBT5, VSBT6 (motorized by MVT44,28,56,57 actuators) still available as spare parts.



2-way globe valves for high close-off applications

2TGA.BT Series 2-way valves **PN16** with pressure balanced plug, compact dimensions, threaded connections up to 2", maximum temperature 120 °C, suitable to applications with high close-off pressure: up to 10 bar close-off. 8,5 mm stroke for MVC203, MVC403 (3 pos.), MVC503 and MVC503R (modulating) actuators.

MODEL	DN	Kvs	MAX. DIFFERENTIAL PRESSURE WITH MVC ACTUATORS	OTHER FEATURES
2TGA20BT	3/4"	5	10 bar	Stainless steel internal parts (seat, plug, stem)
2TGA25BT	1"	10		
2TGA32BT	1 1/4"	13		
2TGA40BT	1 1/2"	18		
2TGA50BT	2"	30		



2TBB Series 2-way valves, bronze body, with threaded connections up to 2", brass plug, stainless steel stem. Temperature applications -10°C to 150°C (Please check on our data sheet DBL244e pressure rating for fluid temperature higher than 120 °C). Rangeability 50:1. To be motorised by MVE and MVH actuators (no adapter needed). 1/2" and 3/4" models are tight close-off. Maximum leakage on 1" to 2" models is 0,1% of Kvs. Stroke on 1/2" and 3/4" models is 9,5 mm. Stroke on 1" to 2" models is 16 mm.

MODEL	DN	Kvs	MAX DIFFERENTIAL PRESSURE [bar]				
			MVE506	MVE510	MVE515	MVE522	MVH56EA/C
2TBB15R1	1/2"	0,2	16	16	16	16	16
2TBB15R2	1/2"	0,5	16	16	16	16	16
2TBB15R3	1/2"	1	16	16	16	16	16
2TBB15	1/2"	2,5	16	16	16	16	16
2TBB20	3/4"	4	16	16	16	16	16
2TBB25	1"	8	11,3	16	16	16	13,2
2TBB32	1 1/4"	12	7,1	12,2	16	16	8,4
2TBB40	1 1/2"	21	4,9	8,4	12,8	16	5,7
2TBB50	2"	33	2,7	4,6	7,1	10,2	3,2



2TBB.T Series 2-way valves, bronze body, with threaded connections up to 2", brass plug, stainless steel stem. Temperature applications -10 °C to 150 °C (Please check on our data sheet DBL521e pressure rating for fluid temperature higher than 120°C). Rangeability 50:1. To be motorised by MVC.03 and MVC503R actuators (no adapter needed). 1/2" and 3/4" models are tight close-off. Maximum leakage on 1" to 2" models is 0,1% of Kvs. Stroke on all models is 12 mm.



MODEL	DN	Kvs	MAX DIFFERENTIAL PRESSURE [bar]
			with MVC actuators
2TBB15T	1/2"	2,5	14,3
2TBB20T	3/4"	4	9,9
2TBB25T	1"	8	5,4
2TBB32T	1 1/4"	12	3,4
2TBB40T	1 1/2"	21	2,3
2TBB50T	2"	33	1,2

FITTINGS FOR THREADED VALVES

MODEL	VALVE SIDE (A)	PIPE SIDE (B) TAPERED	PACK QUANTITY	VALVES
911-2078-010	G 1/2" F	R 3/8"	10	For brass valves 1/2" and 3/4" (e.g. Controlli VSX, VMX, VTX, VSX.T, VMX.T, VTX.T valves)
911-2079-010	G 3/4" F	R 1/2"		

MODEL	VALVE SIDE (A)	PIPE SIDE (B) PARALLEL	VALVES
89811-02	G 1/2" F	G 3/8" M	For brass LIBRA valves 1/2" and 1 1/2" (e.g. Controlli VLX, VLX.P valves)
89811-03	G 3/4" F	G 1/2" M	
89811-01	G 1" F	G 3/4" M	
89811-04	G 1 1/4" F	G 1" M	
89811-05	G 1 1/2" F	G 1 1/4" M	



MODEL	VALVE SIDE (B)	PIPE SIDE (A)	VALVES
89948-01	G 1/2" M	G 1/2" F	For cast iron valves up to 2" (e.g. Controlli VSB-VMB, VSB.T-VMB.T, 2TGB15, 3TGB15, 2TGA.B valves)
89948-02	G 3/4" M	G 3/4" F	
89948-03	G 1" M	G 1" F	
89948-04	G 1 1/4" M	G 1 1/4" F	
89948-05	G 1 1/2" M	G 1 1/2" F	
89948-06	G 2" M	G 2" F	



FLANGED GLOBE VALVES SELECTION CHART



2 = 2 way
3 = 3 way

F = Flanged connections
T = Threaded connections

A = Steel PN40
G = Cast iron PN16
I = Stainless steel PN16, PN40
S = Spheroidal cast iron PN25

A = Stainless steel
B = Brass

BODY

PLUG

VARIANTS

- B = Balanced plug
- P = Extended neck for high temp.
- Rx = Reduced diameter (x=Kvs)
- S = Bellows seal for high temp.
- T = Extended neck and low temp.
- L = Low leak rate (0,01% of the Kvs)

- PS73 = 2FGB / 3FGB with stainless-steel plug
- PS89 = 2FGB / 3FGB with grooved connections suitable to Victaulic clamps

15-200 = DN according to the model



2-way flanged Valves

Series **2F** - **PN16** - Stroke 16.5 mm (DN25), 25 mm (DN40 to 65), 45 mm (DN80 to 150) - To be motorised by MVH - MVE actuators.

MODEL	DN	Kvs	MAX DIFFERENTIAL PRESSURE [bar]							OTHER FEATURES
			MVE506	MVE510	MVE515	MVE522	MVH	MVHE3K	MVH56EA MVH56EC	
2FGB25R4	25R4	4	9,4	15,9	16	16	16	16	11	<ul style="list-style-type: none"> • G 25 cast-iron body • Plug: DN25÷100 Brass, DN125÷150 Bronze • PN16 flanged connections • Fluid temperature: -10 to 150 °C • Control flow characteristics equal-percentage • Leakage 0.03% Kvs
2FGB25R7	25R7	6.3	9,4	15,9	16	16	16	16	11	
2FGB25	25	10	9,4	15,9	16	16	16	16	11	
2FGB32	32	19	5	8,6	13	16	11,7	16	5,9	
2FGB40R19	40R19	19	5	8,6	13	16	11,7	16	5,9	
2FGB40	40	25	5	8,6	13	16	11,7	16	5,9	
2FGB50	50	40	3,1	5,3	8,1	12	7,3	16	3,6	
2FGB65	65	63	1,8	3,1	4,8	7,1	4,3	9,6	2,1	
2FGB80	80	100	1,1	2	3,1	4,6	2,8	6,2	1,3	
2FGB100	100	130	0,7	1,2	1,9	2,9	1,7	3,9	0,8	
2FGB125	125	200	0,4	0,7	1,2	1,8	1	2,4	0,5	
2FGB150	150	300	0,3	0,5	0,8	1,2	0,7	1,6	0,3	
2FGA15R0	15R0	0.6	16	16	16	16	16	16	16	<ul style="list-style-type: none"> • G 25 cast-iron body internal parts in stainless steel • PN16 flanged connections • Fluid temperature: -10 to 200 °C • Equal-percentage control flow characteristic • Leakage 0.02% Kvs
2FGA15R1	15R1	1	16	16	16	16	16	16	16	
2FGA15R2	15R2	1.6	16	16	16	16	16	16	16	
2FGA15R3	15R3	2.5	16	16	16	16	16	16	16	
2FGA15	15	4	16	16	16	16	16	16	16	
2FGA20	20	6.3	12,5	16	16	16	16	16	15,1	
2FGA25	25	10	7,6	14,1	16	16	16	16	9,2	
2FGA32	32	16	7,6	14,1	16	16	16	16	9,2	
2FGA40	40	24	5,1	9,5	15	16	13,4	16	6,2	
2FGA50	50	32	3,3	6,2	9,8	14,8	8,7	16	4	
2FGA65	65	63	1,3	2,5	4	6,1	3,5	8,3	1,6	
2FGA80	80	110	0,8	1,6	2,6	4	2,3	5,5	1	
2FGA100	100	140	0,5	1	1,6	2,5	1,4	3,5	0,6	



In order to avoid seat & plug wearing issues we recommend not to exceed 2 bar (2FGB) & 6 bar (2FGA) differential pressure.
1) For applications with possible ice formation on stem and packing, use the stem heater.

MODEL	DN	Kvs	MAX DIFFERENTIAL PRESSURE [bar]							OTHER FEATURES
			MVE506	MVE510	MVE515	MVE522	MVH	MVHE3K	MVH56EA MVH56EC	
2FGB65L	65	63	1,8	3,1	4,8	7,1	4,3	9,6	2,1	<ul style="list-style-type: none"> • G 25 cast-iron body • Plug: DN65÷100 Brass, DN125÷150 Bronze • PN16 flanged connections • Fluid temperature: -10 to 150 °C • Control flow characteristics equal-percentage • Tight shut-off Leakage= 0,00%
2FGB80L	80	100	1,1	2	3,1	4,6	2,8	6,2	1,3	
2FGB100L	100	130	0,7	1,2	1,9	2,9	1,7	3,9	0,8	
2FGB125L	125	200	0,4	0,7	1,2	1,8	1	2,4	0,5	
2FGB150L	150	300	0,3	0,5	0,8	1,2	0,7	1,6	0,3	



Series **2F** - **PN25-40** - Stroke 16,5 mm (DN25), 25 mm (DN32 to 65), 45 mm (DN80 to 150) - To be motorised by MVE and MVH actuators.

MODEL	DN	Kvs	MAX DIFFERENTIAL PRESSURE [bar]							OTHER FEATURES
			MVE506	MVE510	MVE515	MVE522	MVH	MVHE3K	MVH56EA MVH56EC	
2FSA25R4	25R4	4	18,5	25	25	25	25	25	21,5	<ul style="list-style-type: none"> • Spheroidal cast-iron body internal parts in stainless steel • PN25 flanged connections • Fluid temperature: -10¹⁾ to 230 °C • Equal-percentage control flow characteristic • Leakage 0,02% Kvs
2FSA25R7	25R7	6,3	9,3	15,8	23,9	25	21,5	25	10,8	
2FSA25	25	10	9,3	15,8	23,9	25	21,5	25	10,8	
2FSA32	32	16	6,2	10,6	16,1	23,9	14,5	25	7,3	
2FSA40	40	25	4,4	7,6	11,6	17,2	10,4	23,1	5,2	
2FSA50	50	40	2,8	4,8	7,4	10,9	6,6	14,7	3,3	
2FSA65	65	63	1,6	2,8	4,3	6,4	3,9	8,6	1,9	
2FAA15R2	15R2	1,6	30	30	30	40	30	30	30	<ul style="list-style-type: none"> • Fe 52 steel body internal parts in stainless steel • PN40 flanged connections • Fluid temperature: -10¹⁾ to 230 °C • Equal-percentage control flow characteristic • Leakage 0,02% Kvs
2FAA15	15	4	14,5	32,1	40	40	30	30	18,7	
2FAA20	20	6,3	8,5	19	32,2	40	28,4	30	11,1	
2FAA25	25	10	5,1	11,6	19,8	31,1	17,4	30	6,7	
2FAA32	32	16	5,1	11,6	19,8	31,1	17,4	30	6,7	
2FAA40	40	24	3,4	7,8	13,3	21	11,7	29,2	4,5	
2FAA50	50	32	2,2	5,1	8,7	13,7	7,6	19,1	2,9	
2FAA65	65	63	0,8	2	3,5	5,6	3,1	7,9	1,1	
2FAA80	80	110	0,5	1,3	2,3	3,7	2	5,2	0,7	
2FAA15PR2	15R2	1,6	30	30	40	40	30	30	30	<ul style="list-style-type: none"> • Fe 52 steel body with extended neck internal parts in stainless steel with greaser and special gaskets for high temperatures • PN40 flanged connections • Fluid temperature: -20¹⁾ to 350 °C • Equal-percentage control flow characteristic • Leakage 0,02% Kvs
2FAA15P	15	4	14,5	32,1	40	40	30	30	18,7	
2FAA20P	20	6,3	8,5	19	32,2	40	28,4	30	11,1	
2FAA25P	25	10	5,1	11,6	19,8	31,1	17,4	30	6,7	
2FAA32P	32	16	5,1	11,6	19,8	31,1	17,4	30	6,7	
2FAA40P	40	24	3,4	7,8	13,3	21	11,7	29,2	4,5	
2FAA50P	50	32	2,2	5,1	8,7	13,7	7,6	19,1	2,9	
2FAA65P	65	63	0,8	2	3,5	5,6	3,1	7,9	1,1	
2FAA80P	80	110	0,5	1,3	2,3	3,7	2	5,2	0,7	



In order to avoid seat & plug wearing issues we recommend not to exceed 8 bar (2FSA & 2FAA) & 12 bar (2FAAP) differentiapressure. For applications with possible ice formation on stem and packing, use the stem heater.

1) For fluid applications with temperature below -10 °C, when ordering, add "T" instead of "P" to model, e.g. 2FAA40T.

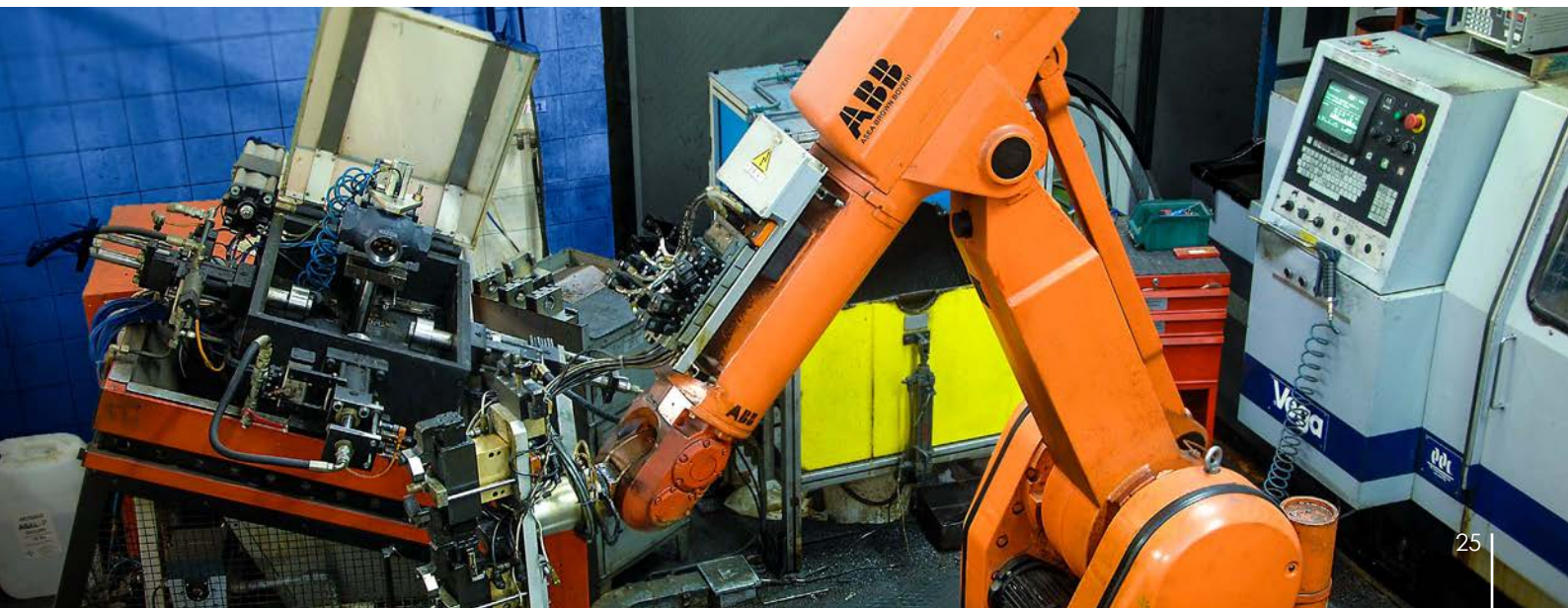

2-way Balanced Plug Valves

Series **2F.B PN16-25-40** Stroke 16,5 mm (DN25), 25 mm (DN40 to 65) 45 mm (DN80 to 150). To be motorised by MVH-MVE actuators.

MODEL	DN	Kvs	MAX DIFFERENTIAL PRESSURE [bar]						OTHER FEATURES
			MVE506	MVE510	MVE515	MVE522	MVH	MVH56EA MVH56EC	
2FGB65B	65	63	10,8	16	16	16	16	14	<ul style="list-style-type: none"> G25 cast iron body Plug: DN65÷100 Brass, DN125÷150 Bronze PN16 flanged connections Fluid temperature: -10¹¹ to 150°C Equal-percentage control characteristic Leakage 0,03% Kvs
2FGB80B	80	100	8	16	16	16	16	10,6	
2FGB100B	100	130	5,3	13,9	16	16	16	7,4	
2FGB125B	125	200	3,5	10,4	16	16	16	5,1	
2FGB150B	150	300	2,1	7,8	15	16	12,9	3,5	
2FSA25BR4	25R4	4	25	25	25	25	25	25	<ul style="list-style-type: none"> Spheroidal cast iron body, stainless steel internal parts PN25 flanged connections Fluid temperature: -10¹¹ to 230°C Equal-percentage control characteristic Leakage 0,02% Kvs
2FSA25BR7	25R7	6,3	25	25	25	25	25	25	
2FSA25B	25	10	25	25	25	25	25	25	
2FSA32B	32	16	25	25	25	25	25	25	
2FSA40B	40	25	24,9	25	25	25	25	25	
2FSA50B	50	40	18,3	25	25	25	25	25	
2FSA65B	65	63	12,2	25	25	25	25	17,6	
2FSA80B	80	100	8,3	25	25	25	25	12,8	
2FAA25B	25	10	30	30	30	40	30	30	
2FAA32B	32	16	30	30	30	40	30	30	<ul style="list-style-type: none"> Steel body and stainless steel internal parts PN40 flanged connections Fluid temperature: -20¹¹ to 230°C Equal-percentage control characteristic Leakage 0,02% Kvs
2FAA40B	40	25	27,6	30	30	40	30	30	
2FAA50B	50	40	21	30	30	40	30	28,1	
2FAA65B	65	63	14,9	30	30	40	30	20,4	
2FAA80B	80	100	11	29,6	30	40	30	15,5	
2FAA100B	100	160	6,5	19,1	30	34,9	30	9,5	
2FAA125B	125	200	4,2	14,3	27,6	27	23,3	6,6	



In order to avoid seat & plug wearing issues we recommend not to exceed 2 bar (2FGBB) & 8 bar (2FSA) & 12 bar (2FAAB) differential pressure.

1) For applications with possible ice formation on stem and packing, use the stem heater.

2-way Double-seat Valves

Series **2FGA.B - 2FAA.B** - Stroke 45 mm - To be motorised by MVH-MVE actuators.

MODEL	DN	Kvs	MAX DIFFERENTIAL PRESSURE [bar]					OTHER FEATURES
			MVE510	MVE515	MVE522	MVH	MVH56EA MVH56EC	
2FAA150B (PN25)	150	300	9,5	20,3	25	17,1	2,9	<ul style="list-style-type: none"> Fe 52 Steel body and stainless steel internal parts PN40 flanged connections Fluid temperature: -10¹¹ ÷ 230°C Equalpercentage control characteristic Leakage 0,12% Kvs
2FGA200B (PN16)	200	500	12	16	16	16	3,7	<ul style="list-style-type: none"> G25 cast iron body, stainless steel internal parts PN16 flanged connections Fluid temperature: -10¹¹ to 200°C Equalpercentage control characteristic Leakage 0,02% Kvs



1) For applications with possible ice formation on stem and packing, use the stem heater.

2FIA series

2-way globe valves **PN16** and **PN40** with stainless steel body and internal parts.
 Fluid temperature range: -30 to +180 °C (Low temperature extension -60 °C)
 PN16 models: DN65, 100
 PN40 models: DN25, 32, 40, 50, 80
 Linear flow characteristic, V-port plug
 2FIA valves are motorized by MVE actuators
 (assembled on the valve in our factory, please include "MVEAV-10" code).

- Valve Body:** Stainless steel AISI 316 ASTM CF8M
- Trim (plug-seat):** 316L
- Stem:** 316L
- Stem Packing:** PTFE
- Plug and Seat sealing:** PTFE
- Actuator:** See data sheets for MVE and MVH actuators
- Valve/Actuator connection:** U-bolt connection



MODEL	DN	FLOW RATE Kvs [m³/h]	STROKE [mm]
2FIA25R4	1"	3,5	20
2FIA25	1"	10	
2FIA32	1 ¼"	16	
2FIA40	1 ½"	24	
2FIA50	2"	42	
2FIA65	2 ½"	63	30
2FIA80	3"	91	
2FIA100	4"	138	

MODEL	DN	MAX DIFFERENTIAL PRESSURE [bar]			
		MVE506	MVE510	MVE515	MVE522
2FIA25R4	25R4	27	-	-	-
2FIA25	25	10	-	-	-
2FIA32	32	5,7	-	-	-
2FIA40	40	4	6,7	-	-
2FIA50	50	2,3	3,9	-	-
2FIA65	65	-	2,4	3,6	-
2FIA80	80	-	-	2,9	4,3
2FIA100	100	-	-	-	2,4



PICVs

Dynamic pressure independent control valves with threaded and flanged connections

Controlli PICVs are ideal for use in heating/cooling variable flow systems and provide constant flow regulation within a given range of differential pressure drop.

Dynamic balancing eliminates overflows regardless of fluctuating pressure conditions in the system.

3 PRODUCTS IN 1

- » Control Valve
- » Differential Pressure Controller
- » Static flow limiting valve

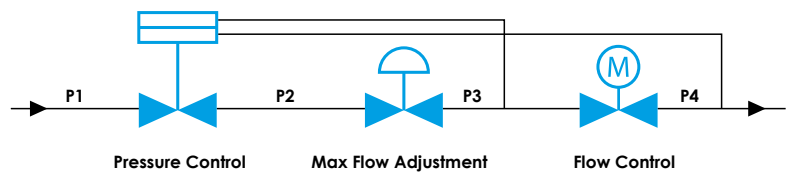

- » One PICV replaces up to three separate valves (a 2-way control valve, a flow limiting valve, a differential pressure control valve)
- » **Constant flow regulation under varying pressure conditions**
- » Optimum control in heating and cooling circuits with variable systems
- » Flow rate can be precisely set at its specified design value
- » Constant differential pressure across the control valve regardless of changes in pump speed or valves closure elsewhere in the system
- » Authority close to 100%
- » Linear valve characteristic regardless of the pre-set value
- » 100% stroke always available regardless pre-set value
- » No cartridge design
- » Very low hysteresis

Easy selection & commissioning

- » Always select the smallest valve capable of delivering the design flow rate
- » Very quick selection also with thousands of units thanks to our **PICV selection tool**
- » Simple commissioning: it is just a matter of selecting one of the pre-set values on the valve caliber
- » Use our formulas for **valve caliber setting** for a quick **flow estimation**
- » Easy ΔP measurement with our DMP700 differential pressure meter (up to 700kPa)



DMP700



LIBRA

VLX PN16 pressure independent control valves are suitable for a wide range of hydronic applications in the building services industry.

Fan-coil units and chilled beams are among the most familiar applications of pressure independent control valves with the move from 4-port (or 3-port) to 2-port valves driven primarily by the need to reduce excessive energy consumption of pumps and thermal losses through pipework.

The design of LIBRA valve combines high performance with small size and compact construction.

MODEL WITH P/T PLUGS	MODEL WITHOUT P/T PLUGS	CONNECTION	DIMENSIONS	STROKE [mm]	MIN. FLOW [l/h]	MAX. FLOW [l/h]	MAX. DIFF. PRESSURE [kPa]
VLX1P	VLX1	1/2" M	DN15	4	100	375	600
VLX2P	VLX2	3/4" M	DN15		145	800	
VLX3P	VLX3	1" M	DN20		200	1000	
VLX4P	VLX4	1 1/4" M	DN25		200	2000	
VLX5P	VLX5	1 1/2" M	DN32		400	4000	
VLX6P	-	1 1/2" F	DN40	15	1100	10000	800
VLX8P	-	2" F	DN50		2200	12500	

BV.P valves can be used in heating and cooling systems that require high flows together with an accurate control; they provide modulating control with full authority regardless of any fluctuations in the differential pressure of the system.

PICVs are 3 devices in one:

- **Static Flow limiting valve:** the flow of the fully open valve can be selected in a range from 30% to 100% by adjusting the setting wheel on the valve.
- **Globe Valve:** the flow can be controlled from 0 up to the maximum set flow by moving the valve plug.
- **Differential Pressure Controller** with the main objective of keeping the pressure drop constant across the valve plug and consequently a flow control not dependent on differential pressure.

BV valves have an equipercentage characteristic.

MODEL	PN	P/T PLUGS	DN	STROKE [mm]	MAX. DIFF. PRESSURE [kPa]	MIN. FLOW [l/h]	MAX. FLOW [l/h]
BV65P	16	•	65	20	800	4200	24100
BV80P	16	•	80	20	800	5900	37300
BV100P	25	•	100	20	1600	1620	50630
BV125P	25	•	125	20	1600	2800	66840



- Valve body:** ductile cast iron
- Valve trim:** stainless steel
- Valve stem:** stainless steel
- Membrane:** EPDM
- Leakage rate:** 0,01% of the Kvs
- Fluids:** chilled water, hot water, glycol (50% max.), from -10°C to 120°C.

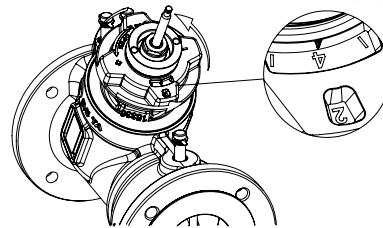

Dynamic balancing eliminates overflows, regardless of fluctuating pressure conditions in the system.

BV.P valves can be supplied with the proper actuator already assembled on the valve.

Pressure Independent Control Valve with diaphragm structure.

BV.P are equipped with pressure plugs, useful to measure the real differential pressure across the valve.

Summary of PICVs

	MODEL		CONNECTION	PN	TEMP. RATING [°C]	STROKE [mm]	MAX. ΔP [kPa]	VALVE BODY MATERIAL	COMPATIBLE ACTUATORS AND MAXIMUM FLOW RATES [l/h]				
	WITH P/T PLUGS	WITHOUT P/T PLUGS							MCA230L MCA24L MVR24/230C2 MVX52B	MVT203S MVT403S MVT503SB MVC503R	MVE204S MVE504S	MVE210 MVE510	MVE215 MVE515
									ELECTRO THERMAL 90N / 140N	ELECTRO MECHANICAL 300N	ELECTRO MECHANICAL 400N	ELECTRO MECHANICAL 1000N	ELECTRO MECHANICAL 1500N
THREADED	VLX1P	VLX1	1/2" M	16	-10÷120	4	600	BRASS	375	375	-	-	-
	VLX2P	VLX2	3/4" M						800	800	-	-	-
	VLX3P	VLX3	1" M						1000	1000	-	-	-
	VLX4P	VLX4	1 1/4" M						2000	2000	-	-	-
	VLX5P	VLX5	1 1/2" M						-	4000	-	-	-
	VLX6P	-	1 1/2" F	16	-10÷120	15	800	CAST IRON	-	-	10000	-	-
VLX8P	-	2" F	-						-	12500	-	-	
FLANGED	BV65P	-	DN65	16	-20÷120	20	800	CAST IRON	-	-	-	24100	-
	BV80P	-	DN80						-	-	-	37300	-
	BV100P	-	DN100	25	-10÷120		1600		-	-	-	-	50630
	BV125P	-	DN125						-	-	-	-	66840

ATTENTION If MVX52B is not powered PICV is OPEN
If MCA24L/MCA230L is not powered PICV is CLOSED

Series **3T** (threaded) - **PN16** - Stroke 11,5 mm. To be motorised by MVB (3TGB.B) - MVE.S (3TGB.F) actuators.

MODEL	DN	Kvs	MAX DIFF. PRESSURE [bar]	ACTUATORS	OTHER FEATURES
3TGB15BR2	1/2"	1,6	13,7	For MVB actuator (or MVT203,403,503 using AG74-03 adapter)	<ul style="list-style-type: none"> GJL-250 cast-iron body Brass internal parts Equal-percentage control flow characteristic Leakage 0 to 0,001% Kvs Female threaded connections: fluid temperature -5¹⁾ to 140 °C, with MVB max 120°C (140 °C with MVB+MVBHT)
3TGB15BR3	1/2"	2,5			
3TGB15B	1/2"	4			
3TGB15FR2	1/2"	1,6	16	For MVE.S actuator	
3TGB15FR3	1/2"	2,5			
3TGB15F	1/2"	4			

In order to avoid seat & plug wearing issues we recommend not to exceed 4 bar differential pressure.
1) For applications with possible ice formation on stem and packing, use the stem heater.



Series **VMB** (threaded) - VMBF (flanged) - **PN16**. To be motorised by MVB - MVE - MVH actuators. - Thermal insulation available.

MODEL	DN	Kvs	MAX DIFFERENTIAL PRESSURE [bar]							OTHER FEATURES
			MVB	MVE506	MVE510	MVE515	MVE522	MVH	MVH56EA MVH56EC	
VMB3	3/4"	6,3	2,6	13,1	16	16	16	16	15,6	<ul style="list-style-type: none"> G 25 cast-iron body Brass internal parts Female threaded connections Fluid temperature: -10¹⁾ to 150°C (with MVB max 120 °C, with MVB+MVBHT max 140 °C) Control characteristic: equal-percentage on direct way, linear on angle way Leakage 0,03% Kvs For MVE actuator, add AG52 linkage For MVH actuator, add AG62 linkage
VMB4	1"	10	1,7	8,7	15,6	16	16	16	10,3	
VMB5	1 1/4"	16	1,1	5,4	9,8	15,4	16	13,7	6,5	
VMB6	1 1/2"	22	0,8	3,9	7,1	11,1	16	9,9	4,7	
VMB8	2"	30	0,6	2,9	5,4	8,4	14,3	7,5	3,5	
VMB8A	2"	40	0,6	2,9	5,4	8,4	14,3	7,5	3,5	
VMB3F	20	6,3	2,6	13,1	16	16	16	16	15,6	<ul style="list-style-type: none"> As above with PN16 slip-on flanges
VMB4F	25	10	1,7	8,7	15,6	16	16	16	10,3	
VMB5F	32	16	1,1	5,4	9,8	15,4	16	13,7	6,5	
VMB6F	40	22	0,8	3,9	7,1	11,1	16	9,9	4,7	
VMB8F	50	30	0,6	2,9	5,4	8,4	14,3	7,5	3,5	
VMB8AF	50	40	0,6	2,9	5,4	8,4	14,3	7,5	3,5	

In order to avoid seat & plug wearing issues we recommend not to exceed 2 bar differential pressure.
1) For applications with possible ice formation on stem and packing, use the stem heater.



Tight Close-Off

Series **VMBP.M** threaded valves - Modulating tight close-off valves **PN16** - Stroke 16,5 mm. Thermal insulation available - To be motorised by MVB actuators.

MODEL	DN	Kvs	MAX DIFFERENTIAL PRESSURE [bar]	OTHER FEATURES
VMBP3M	3/4"	6,3	2 (8,8)	<ul style="list-style-type: none"> G25 cast iron valve body Fluid temperature -5 to 95°C Leakage 0% Kvs
VMBP4M	1"	10	2 (5,5)	
VMBP5M	1 1/4"	16	2 (5,5)	
VMBP6M	1 1/2"	25	2 (2,5)	
VMBP8M	2"	36	1,8	

Values in brackets are max close-off differential pressure. In applications with steam, the value in brackets is not applicable.
In order to avoid seat & plug wearing issues we recommend not to exceed 2 bar differential pressure.



Series **VMB.T** in G25 cast-iron **PN16**. Stroke 5,5 mm - To be motorised by MVC.03 and MVC503R actuators.

MODEL	DN	Kvs	MAX DIFF. PRESSURE [kPa]		OTHER FEATURES
			A-AB	B-AB	
VMB3T	3/4"	6,3	900	700	<ul style="list-style-type: none"> G25 cast iron body Fluid temp. 5 to 95 °C Linear control characteristic Leakage: direct way <0.03% Kvs, angle way < 2% Kvs
VMB4T	1"	10	550	450	
VMB5T	1 1/4"	14	350	300	
VMB6T	1 1/2"	18	250	200	
VMB8T	2"	25	190	160	

Old VMB3, VMB4, VMB5, VMB6, (motorized by MVT44,28,56,57 actuators) still available as spare parts.



3TBB Series 3-way valves, mixing or diverting, bronze valve bodies with threaded connections, brass plug, stainless steel stem. Temperature applications -10°C to 150°C. (Please check on our data sheet DBL244e pressure rating for fluid temperature higher than 120°C). Rangeability 50:1. To be motorised by MVE and MVH actuators (no adapter needed). 1/2" and 3/4" models are tight close-off. Maximum leakage on 1" to 2" models is 0,1% of Kvs. Stroke on 1/2" and 3/4" models is 9,5mm. Stroke on 1" to 2" models is 16mm.

MODEL	DN	Kvs	MAX DIFFERENTIAL PRESSURE [bar]				
			MVE506	MVE510	MVE515	MVE522	MVH56EA MVH56EC
3TBB15	1/2"	2	16	16	16	16	16
3TBB20	3/4"	5	16	16	16	16	16
3TBB25	1"	10	9,7	16	16	16	11,7
3TBB32	1 1/4"	16	6,1	11,2	16	16	7,3
3TBB40	1 1/2"	25	4,2	7,7	12,1	16	5
3TBB50	2"	38	2,3	4,2	6,7	10,6	2,8



3TBB.T Series 3-way valves, mixing or diverting, bronze valve bodies with threaded connections, brass plug, stainless steel stem. Temperature applications -10 °C to 150 °C. (Please check on our data sheet DBL521e pressure rating for fluid temperature higher than 120 °C). Rangeability 50:1. To be motorised by MVC.03 and MVC503R actuators (no adapter needed). 1/2" and 3/4" models are tight close-off. Maximum leakage on 1" to 2" models is 0,1% of Kvs. Stroke on all models is 12 mm.

MODEL	DN	Kvs	MAX DIFFERENTIAL PRESSURE [bar]
			MVC.03, MVC503R
3TBB15T	1/2"	2,5	14,3
3TBB20T	3/4"	4	9,9
3TBB25T	1"	8	5,4
3TBB32T	1 1/4"	12	3,4
3TBB40T	1 1/2"	21	2,3
3TBB50T	2"	33	1,2



Series **3F PN16-25** - Stroke 16,5 mm (DN25), 25mm (DN32-65), 45mm (DN80-150) - To be motorised by MVE - MVH actuators.

MODEL	DN	Kvs	MAX DIFFERENTIAL PRESSURE [bar]							OTHER FEATURES
			MVE506	MVE510	MVE515	MVE522	MVH	MVHE3K	MVH56EA MVH56EC	
3FGB25R4	25R4	4	7	12,7	16	16	16	16	8,4	<ul style="list-style-type: none"> G25 cast-iron body Plug: DN25÷100 Brass, DN125÷150 Bronze PN16 flanged connections Fluid temp.: -10^{ll} to 150 °C Control flow characteristic: direct way: equal-percentage, angle way: linear Leakage: direct-way 0,03% Kvs, angle way 2% Kvs
3FGB25R7	25R7	6,3	7	12,7	16	16	16	16	8,4	
3FGB25	25	10	7	12,7	16	16	16	16	8,4	
3FGB32	32	19	3,9	7,1	11,1	16	9,9	16	4,7	
3FGB40R19	40R19	19	3,9	7,1	11,1	16	9,9	16	4,7	
3FGB40	40	25	3,9	7,1	11,1	16	9,9	16	4,7	
3FGB50	50	40	2,5	4,5	7,1	12	6,3	14,4	3	
3FGB65	65	63	1,5	2,7	4,2	7,1	3,7	8,5	1,7	
3FGB80	80	100	0,9	1,7	2,7	4,6	2,4	5,6	1,1	
3FGB100	100	130	0,6	1,1	1,7	2,9	1,5	3,6	0,7	
3FGB125	125	200	0,4	0,7	1,1	1,8	1	2,3	0,4	
3FGB150	150	300	0,2	0,5	0,7	1,2	0,7	1,6	0,3	
3FSA25R4	25R4	4	9,5	22,2	25	25	25	25	12,5	<ul style="list-style-type: none"> G-308 spheroidal cast-iron body stainless steel internal parts PN25 flanged connections Fluid temp.: -10^{ll} to 230 °C Control flow characteristic: equalpercentage (DN25÷65) linear (DN80), angle way: linear Leakage 0,02% Kvs
3FSA25R7	25R7	6,3	4,7	11,2	19,3	25	16,9	25	6,3	
3FSA25	25	10	4,7	11,2	19,3	25	16,9	25	6,3	
3FSA32	32	19	3,1	7,5	13	23,9	11,4	25	4,2	
3FSA40	40	25	2,2	5,4	9,4	17,2	8,2	20,8	3	
3FSA50	50	40	1,3	3,4	5,9	10,9	5,2	13,3	1,8	
3FSA65	65	63	0,7	1,9	3,4	6,4	3	7,8	1	
3FSA80	80	100	0,7	1,5	2,2	4,2	2,2	5,3	0,9	
3FSA25SR4	25R4	4	5	5	5	5	5	5	5	<ul style="list-style-type: none"> G 308 spheroidal cast-iron body stainless steel internal parts with bellows seal PN25 flanged connections Fluid temp.: -10^{ll} to 300 °C Control flow characteristic: equal percentage (DN25÷65) linear (DN80), angle way: linear Leakage 0,02% Kvs
3FSA25SR7	25R7	6,3	5	5	5	5	5	5	5	
3FSA25S	25	10	5	5	5	5	5	5	5	
3FSA32S	32	16	4,7	5	5	5	5	5	5	
3FSA40S	40	25	3,4	5	5	5	5	5	4,2	
3FSA50S	50	40	2,2	4,2	5	5	5	5	2,7	
3FSA65S	65	63	1,3	2,5	4	5	3,5	5	1,6	
3FSA80S	80	100	0,8	1,6	2,6	4,2	2,3	5	1	



In order to avoid seat & plug wearing issues we recommend not to exceed 2 bar (3FGB) & 8 bar (3FSA & 3FSA S) differential pressure.

1) For applications with possible ice formation on stem and packing, use the stem heater.

MODEL	DN	Kvs	MAX DIFFERENTIAL PRESSURE [bar]							OTHER FEATURES
			MVE506	MVE510	MVE515	MVE522	MVH	MVHE3K	MVH56EA MVH56EC	
3FGB65L	65	63	1,5	2,7	4,2	7,1	3,7	8,5	1,7	<ul style="list-style-type: none"> G25 cast-iron body Plug: DN65÷100 Brass, DN125÷150 Bronze PN16 flanged connections Fluid temp.: -10^{ll} to 150 °C Control flow characteristic: direct way: equal-percentage, angle way: linear Tight shut-off Leakage = 0,00%
3FGB80L	80	100	0,9	1,7	2,7	4,6	2,4	5,6	1,1	
3FGB100L	100	130	0,6	1,1	1,7	2,9	1,5	3,6	0,7	
3FGB125L	125	200	0,4	0,7	1,1	1,8	1	2,3	0,4	
3FGB150L	150	300	0,2	0,5	0,7	1,2	0,7	1,6	0,3	



Series **3F PN40** - Stroke 16,5 mm (DN25), 25mm (DN32-65), 45mm (DN80-125) - To be motorised by MVE-MVH actuators.

MODEL	DN	Kvs	MAX DIFFERENTIAL PRESSURE [bar]							OTHER FEATURES
			MVE506	MVE510	MVE515	MVE522	MVH	MVHE3K	MVH56EA MVH56EC	
3FAA25R4	25R4	4	6	13	21,7	35,3	19,2	30	7,7	<ul style="list-style-type: none"> • Fe 52 steel body stainless steel internal parts • PN40 flanged connections • Fluid temperature: -10¹⁾ to 230 °C • Control flow characteristic: linear • Leakage 0,02% Kvs
3FAA25R7	25R7	6,3	6	13	21,7	35,3	19,2	30	7,7	
3FAA25	25	10	6	13	21,7	35,3	19,2	30	7,7	
3FAA32	32	16	3,8	8,2	13,7	23,9	12,1	30	4,8	
3FAA40	40	25	2,4	5,3	9	15,6	7,9	19,4	3,1	
3FAA50	50	40	1,7	3,7	6,3	10,9	5,6	13,7	2,2	
3FAA65	65	63	1	2,2	3,7	6,4	3,3	8,1	1,3	
3FAA80	80	100	0,6	1,4	2,4	4,2	2,1	5,3	0,8	
3FAA100	100	140	0,4	0,9	1,5	2,6	1,4	3,4	0,5	
3FAA125	125	250	0,2	0,6	1	1,7	0,8	2,1	0,3	
3FAA25PR4	25R4	4	6	13	21,7	35,3	19,2	30	7,7	<ul style="list-style-type: none"> • Fe 52 steel body internal parts in AISI 316 stainless steel with grease-cap and special seals for high temperature • PN40 flanged connections • Fluid temperature: - 25¹⁾ to 350 °C • Control flow characteristics: linear • Leakage 0,02% Kvs
3FAA25PR7	25R7	6,3	6	13	21,7	35,3	19,2	30	7,7	
3FAA25P	25	10	6	13	21,7	35,3	19,2	30	7,7	
3FAA32P	32	16	3,8	8,2	13,7	23,9	12,1	30	4,8	
3FAA40P	40	25	2,4	5,3	9	15,6	7,9	19,4	3,1	
3FAA50P	50	40	1,7	3,7	6,3	10,9	5,6	13,7	2,2	
3FAA65P	65	63	1	2,2	3,7	6,4	3,3	8,1	1,3	
3FAA80P	80	100	0,6	1,4	2,4	4,2	2,1	5,3	0,8	
3FAA100P	100	140	0,4	0,9	1,5	2,6	1,4	3,4	0,5	
3FAA125P	125	250	0,2	0,6	1	1,7	0,8	2,1	0,3	



In order to avoid seat & plug wearing issues we recommend not to exceed 12 bar differential pressure.

1) For applications with fluids -10 °C / -20 °C, when ordering replace letter "P" with letter "T" in the part-number e.g. 3FAA40T
 For applications with fluids -20 °C / -25 °C, when ordering replace letter "P" with letters "TPS132" in the part-number e.g. 3FAA40TPS132

MORE OPTIONS

3FGB valves with stainless steel plug

3FGB valves are also available with stainless steel plug and stainless steel stem packing, both AISI 304. Just add PS73 at the end of the part-number, for example: 3FGB65PS73



"PS89"

2FGB - 3FGB valves with grooved connections suitable to Victaulic clamps
 For example: 3FGB65PS89

3FIA series

3-way mixing globe valves **PN16** and **PN40** with stainless steel body and internal parts.
 Fluid temperature range: -30°C to +180 °C (Low temperature extension -60 °C)

PN16 models: DN65, 100

PN40 models: DN25, 32, 40, 50, 80

Linear flow characteristic, V-port plug

3FIA valves are motorized by MVE actuators

(assembled on the valve in our factory, please include "MVEAV-10" code).

Valve Body: Stainless steel AISI 316 ASTM CF8M

Trim (plug-seat): 316L

Stem: 316L

Stem Packing: PTFE

Plug and Seat sealing: PTFE

Actuator: See data sheets for MVE and MVH actuators

Valve/Actuator connection: U-bolt connection



MODEL	DN	Kvs [m³/h]	STROKE [mm]
3FIA25R4	1"	3,5	20
3FIA25	1"	10	
3FIA32	1 ¼"	16	
3FIA40	1 ½"	24	
3FIA50	2"	42	
3FIA65	2 ½"	63	30
3FIA80	3"	91	
3FIA100	4"	138	

MODEL	DN	MAX DIFFERENTIAL PRESSURE [bar]			
		MVE506	MVE510	MVE515	MVE522
3FIA25R4	25R4	27	-	-	-
3FIA25	25	10	-	-	-
3FIA32	32	5,7	-	-	-
3FIA40	40	4	6,7	-	-
3FIA50	50	2,3	3,9	-	-
3FIA65	65	-	2,4	3,6	-
3FIA80	80	-	-	2,9	4,3
3FIA100	100	-	-	-	2,4



Actuators for small globe valves with spring and PICVs **300 N**

MVT.S - Bidirectional motor for: V.XT brass valves (page 14) and VSXT.PBP PICVs (page 29)

MVT503SB – Only for VLX PICVs (page 29)

IP43 protection.

MVT.S is a compact actuator suitable to motorize small globe valves and PICVs typically used in terminal units where fast control is required. All models provide 300 N force over a maximum stroke of 9 mm.

MVT503S and **MVT503SB** models are equipped with a last generation electronic card that implements diagnostic and an algorithm for auto-calibration of the stroke. They are equipped with 3 LEDs visible through the cover showing the state of operation of the actuator (including errors).

MVT503SB is dedicated to Libra PICVs with 4 mm stroke.

It is possible to limit the maximum stroke of the valve via dipswitch on the board.



MODEL	TIMING [s]	POWER SUPPLY [Vac]	CONSUMPTION [Va]	OTHER FEATURES
MVT203S	11,5 s/mm @ 50 Hz	230	16,2	3 position
MVT403S			2,2	
MVT503S	9,4 s/mm @ 60 Hz	24	3,6	0÷10 / 2÷10 Vdc, 4÷20 mA, proportional control
MVT503SB			3,6	

Actuators for globe valves up to 2" **450 N**

Series **MVB** - Bidirectional motor for VSB - VMB valves with threaded connections ½" to 2" and related versions with flanged connections 15 to 50 mm (VSB.F – VMB.F) and tight shut-off versions (VSBP.M – VMBP.M).

Also suitable to 2TGB15B – 3TGB15B ½" valves (page 20 and 31).

IP50

MVBC: rain-proof protection for all MVB actuators



MODEL	TIMING [s]	POWER SUPPLY [Vac]	CONSUMPTION [Va]	OTHER FEATURES
MVB22	37	230	5	3 position
MVB26	60	230	5	
MVB28	370	230	5	
MVB46	60	24	5	
MVB46P	60	24	5	3 position with 1 kOhm auxiliary potentiometer
MVB36	60	24	5	proportional potentiometric
MVB52	37	24	5	Vdc/ current proportional control. Ranges: 6 to 9, 4 to 7, 8 to 11, 0 to 10, 2 to 10, 1 to 5 Vdc, 4 to 20 mA. Default setting: 0 to 10Vdc
MVB56	60	24	5	
MVBAV	MVB mounting on valve body			





MVC **NEW**

Compact actuator with 300 N force

MVC is a new range of linear actuators designed to motorize globe valves and PICVs used on hot/chilled water systems e.g. AHUs, solar plants, heating / cooling and dehumidification batteries, 2-pipe or 4-pipe FCUs and more. All models provide 300 N force over a maximum stroke of 16 mm.

MVC actuators electronic card is equipped with two micro-switches and a mechanism to ensure a **torque limit** performance.

MVC503 and **MVC503R** proportional models are equipped with a new generation electronic card also featuring diagnostic and self-stroking algorithms. Additionally, 3 LEDs visible through the cover show the operating status of the actuator and alarm.

MVC203 (3 pos., 230 Vac), **MVC403** (3 pos., 24 Vac) and **MVC503** (proportional, 24 Vac) are standard models without emergency return function and speed is **10 s/mm**. They are

perfect for retrofitting purposes to replace actuators from different manufacturers (for example, to motorize MZX, VZX, MEU, FEU, VEU Satchwell valves by means of AG73 linkage kit).

MVC503R (24 Vac/dc) is a special model with **electronic emergency fail-safe function** in case of power loss.

A dip-switch on the PCB allows an easy setting on Normally Open or Normally Closed position. There is a LED dedicated to the charge status of the super-capacitor.

Speed is 5,5 s/mm (3 s/mm when operating in fail-safe mode).

CONTROL SIGNALS:

MVC203 and **MVC403**: On/Off or 3 pos.

MVC503 and **MVC503R**: proportional 0-10 Vdc, 2-10 Vdc, 0-5 Vdc, 6-10 Vdc, 4-20 mA (selectable on the PCB).

Proportional models provide 2-10 Vdc feedback signal.

MODEL	EMERG. RETURN	CONTROL SIGNAL	POWER SUPPLY	SPEED [s/mm]	FORCE [N]	IP	VALVES WITH SPRING				VALVES WITHOUT SPRING			
							VLX / VLX.P	V.XT	VSBT.-VMBT.	VSB.T-VMB.T	2-3TGB15B	2-3TBB.T	2TGA.BT	VALVES OTHER MANUFACTURERS
							3/4" .. 1 1/4"	1/2" .. 3/4"	3/4" .. 1 1/2"	3/4" .. 2"	1/2"	1/2" .. 2"	3/4" .. 2"	STROKE UP TO 16 mm
MVC203	-	3 pos.	230 Vac	10	300	54	STROKE 4 mm	STROKE 5,5 mm	STROKE 5,5 mm	STROKE 5,5 mm	STROKE 11,5 mm	STROKE 12 mm	STROKE 8,5 mm	STROKE UP TO 16 mm
MVC403	-		-				-	-	● (AG74-03)	●	●	●	●	●
MVC503	-		-				24 Vac	-	-	● (AG74-03)	●	●	●	●
MVC503R	●	Prop.	24 Vac/dc	5			●	●	●	● (AG74-03)	●	●	●	● (STROKE max 12 mm)
MVC503R-MB	●	Modbus	24 Vac/dc	5			●	●	●	● (AG74-03)	●	●	●	● (STROKE max 12 mm)



UP TO 2200N FORCE!

MVE

Universal Actuator for globe valves

The MVE is a flexible electro-mechanical actuator for the control of two and three way globe valves in: Heating and Cooling systems, Air handling units, District Heating plants, Industrial Temperature Control systems. The MVE can be controlled either by a proportional (modulating) signal or by an increase/decrease (Floating) signal simply changing switch settings on the field. It is designed for an easy installation to any CONTROLLI flanged valve. Linkage kits are available for threaded valves as well as for valves of other manufacturers.

The Actuator has a fine resolution (500 steps on the full stroke range) for a very accurate fluid control and it is able to self-calibrate on a different stroke without the need of any user action. A Plug&Play function is available as well calibrating the actuator on the valve at the very first power-on only. The MVE implements a smart control algorithm with self diagnostic and alarm functionality in case of unexpected operation,

feedback of alarms to the user is provided by LEDs (Green and Red) on the control board.

MVE is available with standard yoke and with a compact yoke for applications where compact dimensions are required and each version can be available with close-off force 400 N, 600 N, 1000 N, 1500 N and 2200 N.

MVE5.. - MVE5..S

MVE is available with very low voltage power supply 24 Vac or 24Vdc.

MVE2.. - MVE2..S

MVE is also available with high voltage power supply 230Vac with the same functionality of the 24Vac/dc

* **MVE2... - MVE2...S are not UL Listed.**



MODEL		TIMING [s]				3P.	POWER SUPPLY [Vca]		FORCE [N]	IP	MORE FEATURES
		STROKE [mm]			MVE5..		MVE2..				
		5/15	15/25	25/60							
MVE504	MVE204*	15 s	20 s	30 s	60 s	24	230	400	IP54	Control 3p floating and proportional switch selectable. Control range 0..10 Vdc, 2..10 Vdc, 0..5 Vdc, 5..10 Vdc, 2..6 Vdc, 6..10 Vdc and 4-20 mA STROKE 5-60 mm	
MVE506	MVE206*							600			
MVE510	MVE210*							1000			
MVE515	MVE215*							1500			
MVE522	MVE222*							2200			
MVE504S	MVE204S*	15 s	20 s	30 s	60 s	24	230	400	IP54	Control 3p floating and proportional switch selectable. Control range 0..10 Vdc, 2..10 Vdc, 0..5 Vdc, 5..10 Vdc, 2..6 Vdc, 6..10 Vdc and 4-20 mA STROKE 5-30 mm Short Yoke	
MVE506S	MVE206S*							600			
MVE510S	MVE210S*							1000			
MVE515S	MVE215S*							1500			
MVE522S	MVE222S*							2200			
MVEAV		MVE assembly on valve body									

MVE.R

Electric actuators with Emergency fail safe function



All features such as input/output signals, automatic or manual calibration, diagnostic, resolution, auxiliary end switches, manual override etc. are the same as standard MVE actuators. Additionally MVE.R provide electronic emergency function based on super-capacitor technology in the event of a power failure.

Emergency position (**retracted or extended stem**) selectable by PC board. Opening/closing times, also in case of emergency return: approx. 1 mm/s for proportional control or 60 s (regardless of valve stroke) for floating control. One model provides both stem up / stem down options, through jumper setting. Charging time about 130 s. Super-capacitor life: 10 years

MVE.R actuators can be controlled either by a proportional (modulating) signal or by an increase/decrease (floating) signal.

It is easy to mount and connect the actuator onto a valve. Direct mounting is possible to any CONTROLLOI flanged valve. Linkage kits are available for CONTROLLOI threaded valves as well as for valves of other manufacturers. Thanks to self stroking functionality and

availability of various linkage kits, these actuators can also fit on many valves from other manufacturers.

MVE.R actuators have an excellent resolution (500 steps along the whole stroke range) for very accurate flow control and are able to self-calibrate on different stroke values without any operation by the installer (this function is DIP switch selectable on site).

More over, MVE.R actuators are provided with a self diagnostic functionality very useful in case of unexpected situations and in such an event the green and red LEDs on the electronic board will blink. Examples of faulty conditions that are detected:

- stroke out of range 5-60 mm;
- unexpected stall condition (e.g. valve is stuck);
- missing expected stall condition (e.g. valve/actuator connection is loose);
- voltage supply out of range.



MODEL		TIMING [s]				3P	POWER SUPPLY		FORCE [N]	IP	MORE FEATURES
		STROKE [mm]			MVE5..		MVE2..				
		5/15	15/25	25/60							
MVE504R	MVE204R	15 s	20 s	25 s	60 s	24 Vac/dc	230 Vac	400	IP54	Control 3p floating and proportional switch selectable. Control range 0..10 Vdc, 2..10 Vdc, 0..5 Vdc, 5..10 Vdc, 2..6 Vdc, 6..10 Vdc and 4-20 mA STROKE 5-60 mm Emergency position (stem up / stem down) selectable with jumper setting on the PCBA. Supercapacitor charging time after power off 130s	
MVE506R	MVE206R							600			
MVE510R	MVE210R							1000			
MVE515R	MVE215R							1500			
MVE504SR	MVE204SR	15 s	20 s	25 s	60 s	24 Vac/dc	230 Vac	400	IP54	Control 3p floating and proportional switch selectable. Control range 0..10 Vdc, 2..10 Vdc, 0..5 Vdc, 5..10 Vdc, 2..6 Vdc, 6..10 Vdc and 4-20 mA STROKE 5-30 mm Short Yoke Emergency position (stem up / stem down) selectable with jumper setting on the PCBA. Supercapacitor charging time after power off 130s	
MVE506SR	MVE206SR							600			
MVE510SR	MVE210SR							1000			
MVE515SR	MVE215SR							1500			
MVEAV		MVE assembly on valve body									

MORE PROTECTION FOR MORE PERFORMANCE

MVE IP65

Electric actuators with protection degree IP65

“Totally protected against dust and water jets from any direction”



MODEL		TIMING [s]				POWER SUPPLY		FORCE [N]	MORE FEATURES
		STROKE [mm]			3P.	MVE5..	MVE2..		
		5/15	15/25	25/60					
MVE504-65	MVE204-65	15 s	20 s	30 s	60 s	24 Vac/dc	230 Vac	400	Control 3p floating and proportional switch selectable. Control range 0..10 Vdc, 2..10 Vdc, 0..5 Vdc, 5..10 Vdc, 2..6 Vdc, 6..10 Vdc and 4-20 mA. STROKE 5-60 mm
MVE506-65	MVE206-65							600	
MVE510-65	MVE210-65							1000	
MVE515-65	MVE215-65							1500	
MVE522-65	MVE222-65							2200	
MVE504S-65	MVE204S-65	15 s	20 s	30 s	60 s	24 Vac/dc	230 Vac	400	Control 3p floating and proportional switch selectable. Control range 0..10 Vdc, 2..10 Vdc, 0..5 Vdc, 5..10 Vdc, 2..6 Vdc, 6..10 Vdc and 4-20 mA. STROKE 5-30 mm. Short Yoke
MVE506S-65	MVE206S-65							600	
MVE510S-65	MVE210S-65							1000	
MVE515S-65	MVE215S-65							1500	
MVE522S-65	MVE222S-65							2200	
MVE504R-65	MVE204R-65	15 s	20 s	25 s	60 s	24 Vac/dc	230 Vac	400	Control 3p floating and proportional switch selectable. Control range 0..10 Vdc, 2..10 Vdc, 0..5 Vdc, 5..10 Vdc, 2..6 Vdc, 6..10 Vdc and 4-20 mA. STROKE 5-60 mm Emergency position (stem up / stem down) selectable with jumper setting on the PCBA. Supercapacitor charging time after power off 130s.
MVE506R-65	MVE206R-65							600	
MVE510R-65	MVE210R-65							1000	
MVE515R-65	MVE215R-65							1500	
MVE506SR-65	MVE206SR-65	15 s	20 s	25 s	60 s	24 Vac/dc	230 Vac	400	Control 3p floating and proportional switch selectable. Control range 0..10 Vdc, 2..10 Vdc, 0..5 Vdc, 5..10 Vdc, 2..6 Vdc, 6..10 Vdc and 4-20 mA. STROKE 5-30 mm Short Yoke Emergency position (stem up / stem down) selectable with jumper setting on the PCBA. Supercapacitor charging time after power off 130s.
MVE506SR-65	MVE206SR-65							600	
MVE510SR-65	MVE210SR-65							1000	
MVE515SR-65	MVE215SR-65							1500	



Globe Valve Actuators 1500 N-3000 N

Series **MVH** - For all valve bodies, self-adjusting stroke 10 to 45 mm (9 to 50 mm for MVH56E)
 - For VSB-VSB.F VMB-VMB.F valves only, add linkage AG62, - Manual override - Protection IP55.

MODEL	TIMING DEPENDING ON VALVE STROKE [seconds]			SUPPLY [Vac]	CON-SUMPTION [VA]	FORCE [N]	ACTION
	16,5	25	45				
MVH26	22	33	60	230	12	1500	on/off floating
MVH46	22	33	60	24	12		proportional potentiometric
MVH36	22	33	60	24	12		proportional control selectable range for industrial applications
MVH56	22	33	60	24	12		3-position and/or proportional control (selectable) Ranges: 6 to 9/4 to 7/8 to 11/0 to 10/2 to 10/1 to 5 Vdc; current 4 to 20 mA. Default setting: 0 to 10Vdc
MVH56E	26	40	70	24	12	3000	3-position and/or proportional control (selectable) Ranges: 6 to 9/4 to 7/8 to 11/0 to 10/2 to 10/1 to 5 Vdc; current 4 to 20 mA. Default setting: 0 to 10Vdc
MVHE3K	26	40	70	24	25		
MVHAV	MVH assembly on valve body						



Globe Valve Actuators with Spring Return 700 N

Series **MVH** - For all valve bodies, self-adjusting stroke 9 to 50 mm - Direct-reverse action -
 For VSB-VSBF VMB-VMBF valves only, add linkage AG62 - Protection IP55.

MODEL	TIMING DEPENDING ON VALVE STROKE [seconds] ¹⁾			SUPPLY [Vac]	CON-SUMPTION [VA]	ACTION	OTHER FEATURES
	16,5	25	45				
MVH56EA	17 (45)	25 (60)	48 (114)	24	15	Vdc/mA proportional control or floating control. Default setting: 0 to 10Vdc	with spring return stem up
MVH56EC	17 (45)	25 (60)	48 (114)	24	15		with spring return stem down

1) The values in brackets indicate the return time by spring return. By spring return: MVHEA closes two-way valves and direct way in three-way valves, MVHEC opens two-way valves and direct way in three-way valves. This is valid for all valves except 2FGA, 2FGA.B, 2FAA, 2FAA150B in which it happens the opposite.



Action of spring return on power failure

2 WAY VALVES		
SPRING ACTION ON POWER FAILURE		
VALVE	MVH56EA	MVH56EC
VSB	VALVE CLOSED	VALVE OPEN
VSB.F	VALVE CLOSED	VALVE OPEN
2TBB	VALVE CLOSED	VALVE OPEN
2FGB	VALVE CLOSED	VALVE OPEN
2FGA	VALVE OPEN	VALVE CLOSED
2FSA	VALVE CLOSED	VALVE OPEN
2FAA	VALVE OPEN	VALVE CLOSED
2FAA.P	VALVE OPEN	VALVE CLOSED
2FGB.B	VALVE CLOSED	VALVE OPEN
2FSA.B	VALVE CLOSED	VALVE OPEN
2FAA.B	VALVE CLOSED	VALVE OPEN
2FAA150B/2FGA200B	VALVE OPEN	VALVE CLOSED

3 WAY VALVES		
SPRING ACTION ON POWER FAILURE		
VALVE	MVH56EA	MVH56EC
VMB	DIRECT WAY CLOSED	DIRECT WAY OPEN
VMB.F	DIRECT WAY CLOSED	DIRECT WAY OPEN
3TBB	DIRECT WAY CLOSED	DIRECT WAY OPEN
3FGB	DIRECT WAY CLOSED	DIRECT WAY OPEN
3FSA	DIRECT WAY CLOSED	DIRECT WAY OPEN
3FSA.S	DIRECT WAY CLOSED	DIRECT WAY OPEN
3FAA	DIRECT WAY CLOSED	DIRECT WAY OPEN
3FAA.P	DIRECT WAY CLOSED	DIRECT WAY OPEN

Linkage kits

MODEL	DESCRIPTION
AF24	LINKAGE KIT FOR MDL ON VALVES VFA DN25-100
AF25	LINKAGE KIT FOR MDL ON VALVES VFA DN125-200
AG22	LINKAGE KIT FOR MVB ON V500
AG40	LINKAGE KIT FOR MVB ON VB7200/7300
AG51	LINKAGE KIT FOR MVE-MVH ON VALVES VMB16, VBG, VSG (45 MM STROKE) AND SS, DS, 3V, VSS, VBS, VMS, VBAA
AG52	LINKAGE KIT FOR MVE ON THREADED VALVES VSB, VMB AND VSB.F, VMB.F
AG53	LINKAGE KIT FOR MVE ON VALVES SATCHWELL
AG54	LINKAGE KIT FOR MVH ON VALVES SATCHWELL
AG60-07	LINKAGE KIT FOR MVE ON VALVES DANFOSS
AG60-10/79	LINKAGE KIT FOR MVE ON VALVES HONEYWELL
AG62	LINKAGE KIT FOR MVH ON VALVES THREADED VSB, VMB AND VSB.F, VMB.F
AG63	LINKAGE KIT FOR MVE.S ON VALVES THREADED VSB, VMB AND VSB.F, VMB.F
AG64	LINKAGE KIT FOR MVH ON OLD VALVES SS-DS-VM-3V DN15÷65 LINKAGE KIT FOR MVLHT

MODEL	DESCRIPTION
AG65	LINKAGE KIT FOR MVH ON OLD VALVES SS-DS-VM-3V DN ≥80 LINKAGE KIT FOR MVLHT
AG66	LINKAGE KIT FOR MVE ON VALVES JOHNSON CONTROL VB7816
AG69	LINKAGE KIT FOR MVE ON VALVES MUT
AG72	LINKAGE KIT FOR MVA ON VALVES MICRA ®
AG73	LINKAGE KIT FOR MVT203, MVT403, MVT503 ON VALVES SATCHWELL MZX, VZX, FEU, MEU, VEU
AG70-10/70-14	LINKAGE KIT FOR MVE ON VALVES SIEMENS
AM71	LINKAGE KIT FOR MDB ON SHOE VALVES LAZZARI
AM72	LINKAGE KIT FOR MDB ON SHOE VALVES M3 & M4
AG74-01	LINKAGE KIT FOR MVC AND MVT.03 ON VALVES VSB.T-VMB.T AND 2TGA.BT
AG74-03	LINKAGE KIT FOR MVC AND MVT.03 ON VALVES 2-3TGB.B
AG81	LINKAGE KIT FOR MVH WITH VALVES 2-3FIA
AG82	LINKAGE KIT FOR MVE WITH VALVES BELIMO H2...X-S and H3...X-S

Insulation Jackets for 2 & 3 way valves

(Supplied separately from the valve body, mounting to be arranged by the user)

MODEL	DESCRIPTION
54304-01	THERMAL INSULATION FOR VSXT09P, VSXT10P, VSXT11P, VSXT12P, VSXT13P, VSXT1P AND VSX09P, VSX10P, VSX11P, VSX12P, VSX13P, VSX1P
54304-02	THERMAL INSULATION FOR VSXT21P AND VSX21P
54304-03	THERMAL INSULATION FOR VMXT09P, VMXT10P, VMXT11P, VMXT12P, VMXT13P, VMXT1P AND VMX09P, VMX10P, VMX11P, VMX12P, VMX13P, VMX1P
54304-04	THERMAL INSULATION FOR VMXT21P AND VMX21P
54304-05	THERMAL INSULATION FOR VTX09P, VTX10P, VTX11P, VTX12P, VTX13P, VTX1P AND VTX09P, VTX10P, VTX11P, VTX12P, VTX13P, VTX1P
54304-06	THERMAL INSULATION FOR VTX09P4, VTX10P4, VTX11P4, VTX12P4, VTX13P4 AND VTX09P4, VTX10P4, VTX11P4, VTX12P4, VTX13P4
54304-07	THERMAL INSULATION FOR VTX21P AND VTX21P
54304-08	THERMAL INSULATION FOR VSXT24P, VSXT26P AND VSX24P, VSX26P
54304-09	THERMAL INSULATION FOR VMXT24P, VMXT26P AND VMX24P, VMX26P
54304-10	THERMAL INSULATION FOR VTX24P, VTX26P AND VTX24P, VTX26P
55047-015	THERMAL INSULATION FOR VLX1, VLX1P, VLX2 AND VLX2P VALVES
55047-020	THERMAL INSULATION FOR VLX3 AND VLX3P VALVES
55047-025	THERMAL INSULATION FOR VLX4 AND VLX4P VALVES
55047-032	THERMAL INSULATION FOR VLX5 AND VLX5P VALVES
55047-040	THERMAL INSULATION FOR VLX6P VALVES
55047-050	THERMAL INSULATION FOR VLX8P VALVES
GVB15	THERMAL INSULATION FOR 3TGB15B AND 3TGB15F
GVB3	THERMAL INSULATION FOR VSB3, VMB3, VSB3F, VMB3F, VSB3T, VMB3T, DN 3/4"
GVB4	THERMAL INSULATION FOR VSB4, VMB4, VSB4F, VMB4F, VSB4T, VMB4T, DN 1"

MODEL	DESCRIPTION
GVB5	THERMAL INSULATION FOR VSB5, VMB5, VSB5F, VMB5F, VSB5T, VMB5T, DN 1 1/4"
GVB6	THERMAL INSULATION FOR VSB6, VMB6, VSB6F, VMB6F, VSB6T, VMB6T, DN 1 1/2"
GVB8	THERMAL INSULATION FOR VSB8, VMB8, VSB8F, VM8F, VSB8T, VMB8T, DN 2", KV30
GVB8A	THERMAL INSULATION FOR VSB8A, VMB8A, VSB8AF, VM-B8AF, DN 2", KV40
GVB40	THERMAL INSULATION FOR 2FGB40 AND 3FGB40
GVB50	THERMAL INSULATION FOR 2FGB50 AND 3FGB50
GVB65	THERMAL INSULATION FOR 2FGB65 AND 3FGB65
GVB80	THERMAL INSULATION FOR 2FGB80 AND 3FGB80
GVB100	THERMAL INSULATION FOR 2FGB100 AND 3FGB100
GVB125	THERMAL INSULATION FOR 2FGB125 AND 3FGB125
GVB150	THERMAL INSULATION FOR 2FGB150 AND 3FGB150
GVB40PS89	THERMAL INSULATION FOR 2FGB40PS89 AND 3FGB40PS89
GVB50PS89	THERMAL INSULATION FOR 2FGB50PS89 AND 3FGB50PS89
GVB65PS89	THERMAL INSULATION FOR 2FGB65PS89 AND 3FGB65PS89
GVB80PS89	THERMAL INSULATION FOR 2FGB80PS89 AND 3FGB80PS89
GVB100PS89	THERMAL INSULATION FOR 2FGB100PS89 AND 3FGB100PS89
GVB125PS89	THERMAL INSULATION FOR 2FGB125PS89 AND 3FGB125PS89
GVB4PS150	THERMAL INSULATION FOR VSB4PS150, VMB4PS150, VSB4TPS150, VMB4TPS150, DN 1"
GVB5PS150	THERMAL INSULATION FOR VSB5PS150, VMB5PS150, VSB5TPS150, VMB5TPS150, DN 1 1/4"
GVB6PS150	THERMAL INSULATION FOR VSB6PS150, VMB6PS150, VSB6TPS150, VMB6TPS150, DN 1 1/2"
GVB8PS150	THERMAL INSULATION FOR VSB8PS150, VMB8PS150, VSB8TPS150, VMB8TPS150, DN 2", KV30
GVB8APS150	THERMAL INSULATION FOR VSB8APS150, VMB8APS150, DN 2", KV40

Accessories for Actuators

MODEL	DESCRIPTION
244	STEM HEATER 24VAC FOR MVB ACTUATORS ON VSB, VMB, VSB.F, VMB.F VALVES
248	STEM HEATER 24VAC FOR MVH AND MVE ACTUATORS WITH THREADED OR FLANGED VALVES
D36	ONE STROKE-END AUXILIARY MICROSWITCH ADJUSTABLE ON THE WHOLE STROKE FOR MVB
DMDA	TWO AUXILIARY MICROSWITCHES FOR MDA (PAG.42)
DMVE	TWO AUXILIARY MICROSWITCHES FOR MVE, MVH..E
DMVH	TWO AUXILIARY MICROSWITCHES ADJUSTABLE ON THE WHOLE STROKE FOR MVH
MVBC	RAIN-PROOF PROTECTION
MVBD	MICROSWITCH DRIVEN BY MANUAL CONTROL KNOB. SUPPLIED ONLY FACTORY-MOUNTED
MVBHT	SPACER FOR MVB. TO BE USED WITH V.B/V.BF VALVES WITH TEMPERATURE FROM 120 TO 140 °C
MVHPA2	1000 OHM AUXILIARY POTENTIOMETER FOR MVH26
MVHPA4	1000 OHM AUXILIARY POTENTIOMETER FOR MVH46
MVHT	SPACER FOR HIGH TEMPERATURE FOR MVH. TO BE USED WITH VALVE BODIES WITH FLUID TEMPERATURE HIGHER THAN 150°C (2F-3F)

All accessories, except MVBD, are supplied separately. Mounting is carried out by the user.

Flanges Options

MODEL	DESCRIPTION
A125-2	DRILLED FLANGES WITH ANSI (ASA) 125 BOLT HOLES FOR 2-WAY VALVES 2FGA.B, 2FGB, 2FGB.B, 2FSA (DN50 TO 65), 2FSA.B (DN50 TO 80), 2FGA (DN25, 32, 50, 65)
A125-3	DRILLED FLANGES WITH ANSI (ASA) 125 BOLT HOLES FOR 3-WAY VALVES 3FGB, 3FSA (DN50 TO 65)
A150-2	DRILLED FLANGES WITH ANSI (ASA) 150 BOLT HOLES FOR 2-WAY VALVES 2FAA150B, 2FSA (DN50 TO 65), 2FSA.B (DN50 TO 80), 2FAA.B (DN50 TO 125), 2FAA (DN32 TO 65)
A150-3	DRILLED FLANGES WITH ANSI (ASA) 150 BOLT HOLES FOR 3-WAY VALVES 3FAA (DN50 TO 125), 3FSA (DN50 TO 65)
A300-2	DRILLED FLANGES WITH ANSI (ASA) 300 BOLT HOLES FOR 2-WAY VALVES 2FSA, 2FSA.B, 2FAA.B (DN32 TO 65 AND DN100 TO 125), 2FAA (DN15 AND DN32 TO 65)
A300-3	DRILLED FLANGES WITH ANSI (ASA) 300 BOLT HOLES FOR 3FSA, 3FAA (DN32 TO 65 AND DN100 TO 125)

Insulation jackets

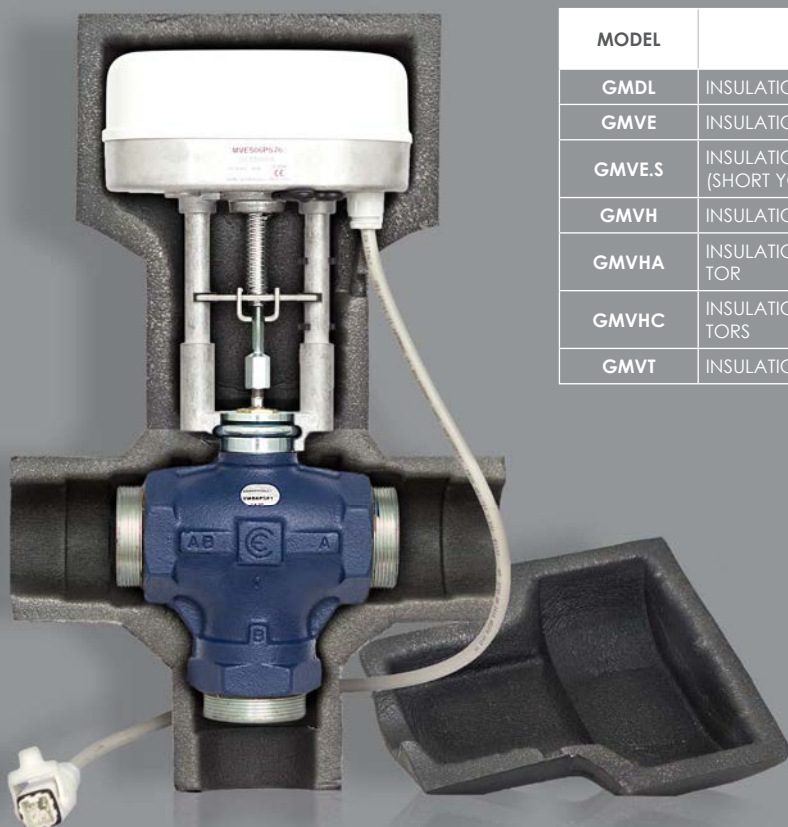

MODEL	DESCRIPTION
GMDL	INSULATION JACKETS (2X SHELL WITH VELCRO STRIPS) FOR MDL ACTUATORS
GMVE	INSULATION JACKETS (2X SHELL WITH VELCRO STRIPS) FOR MVE ACTUATORS
GMVE.S	INSULATION JACKETS (2X SHELL WITH VELCRO STRIPS) FOR MVE_S ACTUATORS (SHORT YOKE)
GMVH	INSULATION JACKETS (2X SHELL WITH VELCRO STRIPS) FOR MVH ACTUATORS
GMVHA	INSULATION JACKETS (2X SHELL WITH VELCRO STRIPS) FOR MVH56EA ACTUATORS
GMVHC	INSULATION JACKETS (2X SHELL WITH VELCRO STRIPS) FOR MVH56EC ACTUATORS
GMVT	INSULATION JACKETS FOR MVT 300 N ACTUATORS

Motorized Ball valves with characterized flow control

“New performing range of brass valves with chrome plated brass balls and electric rotary actuators with high IP level”



Ball valves range



- **2-way** and **3-way** valves (mixing/diverting) with high Kvs values
- Tight close-off (**0% leakage**)
- Fluids temperature from **-20°C to +130°C**
- Up to **10 bar close-off pressure**
- Valve bodies with high pressure rates **PN32** and **PN40**
- **Equal percentage flow curve** for modulating models only

	MODEL	TYPE	DN	Kvs [m³/h]	P max [bar]	ACTUATOR	DELTA P [bar]	FLUID TEMPERATURE	
								MIN.	MAX.
ON - OFF	VSS2	2-way	1/2"	20	32	10 Nm	10	-20 °C	+130 °C
	VSS3		3/4"	45					
	VSS4		1"	60					
	VSS5		1 ¼"	100					
	VSS6		1 ½"	120					
	VSS8		2"	220					
	VSD3	3-way diverting	3/4"	9,6	16	16 Nm	3,5	-15 °C	+110 °C
	VSD4		1"	11,3					
	VSD5		1 ¼"	19,2					
	VSD6		1 ½"	27,7					
	VSD8		2"	57					
	VSD8-63		2"	63					
MODULATING	VSC2	2-way	1/2"	4	16	16 Nm	3,5	-10 °C	+130 °C
	VSC3		3/4"	6,3					
	VSC4		1"	10					
	VSC5		1 ¼"	16					
	VSC6		1 ½"	25					
	VSC8		2"	40					
	VDC2	3-way mixing	1/2"	4	16	16 Nm	3,5	-10 °C	+130 °C
	VDC3		3/4"	6,3					
	VDC4		1"	10					
	VDC5		1 ¼"	16					
	VDC6		1 ½"	25					
	VDC8		2"	40					
	VDC8-63		2"	63					

Actuators range

- No need of stem heater with fluids below 0 °C: the actuator has its own system to prevent ice
- High protection degree **IP65** on most actuators
- Auxiliary micro-switches on all actuators
- Opening or closing time: 40 seconds (10 Nm models) or 60 seconds (16 Nm models)
- Manual override



10 Nm



16 Nm

	MODEL	POWER SUPPLY	TORQUE [Nm]	OPENING AND CLOSING TIME [seconds]	AUX. END SWITCH	IP RATING	MANUAL OVERRIDE
ON - OFF	MVS210	230 Vac	10	40	YES	IP 42	NO
	MVS410	24 Vac					
	MVS216	230 Vac	16	60		IP 65	YES
	MVS416	24 Vac					
3p	MVS416F	24 Vac	16	60	YES	IP 65	YES
0 ÷ 10 Vdc	MVS516	24 Vac/dc	16	60	NO	IP 65	YES

Accessories

CODE	DESCRIPTION
MVSHT	Spacer for MVSx16 actuator useful in case of high temperature fluids or when insulation is needed (chilled water)

Valves / Actuators cross reference

VALVES SERIES	CONTROL	TYPE	DN	Kvs	ACTUATORS		
					MVSx10 10 Nm	MVSx16 16 Nm	MVS516 16 Nm
					ON - OFF	ON - OFF / 3P	0 ÷ 10 Vdc
VSS	On - Off	2-way	1/2" ÷ 1 1/4"	20 ÷ 100	✓		
			1 1/2" ÷ 2"	120 ÷ 220		✓	
VSD		3-way diverting	3/4" ÷ 1"	9.6 ÷ 11.3	✓		
			1 1/4" ÷ 2"	19.2 ÷ 57		✓	✓
VSC	0 ÷ 10 Vdc	2-way	1/2" ÷ 2"	4 ÷ 40		✓	✓
VDC		3-way mixing	1/2" ÷ 2"	4 ÷ 40		✓	✓

Butterfly valves

Series **VFA** - The valves are ready for mounting on MDA actuators. They can also be motorized by MDL actuators (page 42) by means of AF24 and AF25 adapters.

MODEL	DN	Kvs	MAX DIFFERENTIAL PRESSURE [bar]		OTHER FEATURES	
			MDA22/42/52	MDA24/44/54		
			MDL24/44/54 20Nm	MDL26/46/56 30Nm		
VFA	25	26	6	-	<ul style="list-style-type: none"> • PN16 (PN6, PN10) • Spheroidal cast-iron body (EN-JS1030) • Shaft tight O-Ring • Seat EPDM • Fluid temp.: -10 to 100°C • Close-off leakage: leakage rate A (DIN EN 12266-1) 	
	32	27		-		
	40	50		-		
	50	116		-		
	65	259		-		
	80	377		-		
	100	763		-		
	125	1030		-		6
	150	1790		-		3
	200	3460		-		



Actuators for Butterfly valves, dampers, burners

Series **MDL** - Bidirectional motor- Input signal P.C. board - Power consumption 12VA - 2 output shafts: main and secondary shaft Ø 9,5 x 9,5 mm - MDL30-50 angular travel set at 90°adjustable between 55 and 160°- MDL20-40-60 angular travel set at 90°adjustable between 0 and 160° - Force 500 N - Manual override - IP 55.

MODEL	TIMING [s. FOR 90°]	TORQUE [Nm]	ADJUSTABLE ANGULAR TRAVEL	SUPPLY [Vac]	MAX DAMPER SURFACE [m²]	ACTION
MDL22	15 - 27	6	0 to 160	230	1,2	On/off, floating
MDL24	45 - 80	20	0 to 160	230	4	"
MDL26	60 - 107	30	0 to 160	230	6	"
MDL42	15 - 27	6	0 to 160	24	1,2	"
MDL44	45 - 80	20	0 to 160	24	4	"
MDL46	60 - 107	30	0 to 160	24	6	"
MDL62	15 - 27	6	0 to 160	110	1,2	"
MDL64	45 - 80	20	0 to 160	110	4	"
MDL66	60 - 107	30	0 to 160	110	6	"
MDL32	15 - 27	6	55 to 160	24	1,2	Proportional-potentiometric (165 Ohm)
MDL34	45 - 80	20	55 to 160	24	4	
MDL36	60 - 107	30	55 to 160	24	6	
MDL52	15 - 27	6	55 to 160	24	1,2	Vdc/current proportional control. Ranges: 6 to 9, 4 to 7, 8 to 11, 0 to 10, 1 to 5 Vdc, or current 4 to 20 mA
MDL54	45 - 80	20	55 to 160	24	4	
MDL56	60 - 107	30	55 to 160	24	6	



VARIANTS: in case the MDL2./4. actuators are needed to be supplied with 1 KOhm auxiliary potentiometer, add PA2 for MDL2",", PA4 for MDL4",," and PA6 for MDL6",,"; e.g. MDL24PA2, MDL46PA4 or MDL66PA6. In special applications, the actuators can be supplied with 2 or 3 auxiliary potentiometers.

Actuators for Butterfly valves

Series **MDA** - Bidirectional actuator for VFA butterfly valves - Floating (MDA2.-4.) or proportional 0-10 V (MDA5.) control signal - Angular stroke 90° - Manual control - Supplied with linkage for mounting on valve body - Protection IP54.

MODEL	TIMING [s]	POWER SUPPLY	TORQUE [Nm]	ACTION	OTHER FEATURES
MDA22	90	230 Vac 50/60 Hz	20	Floating	For VFA valves up to DN100
MDA24	150		40	Floating	For VFA valves from DN125 to DN200
MDA42	90	24 Vac/dc	20	Floating	For VFA valves up to DN100
MDA44	150		40	Floating	For VFA valves from DN125 to DN200
MDA52	90		20	Proportional 0-10 V	For VFA valves up to DN100
MDA54	150		40	Proportional 0-10 V	For VFA valves from DN125 to DN200
MDAV1	MDA actuators are supplied NOT mounted on valve bodies. In case the actuator-valve assembly is required, order the specific part number MDAV1 together with the models of actuator and valve body.				
MDAV2	DMDA microswitch assembling on MDA actuator				

OPTIONS

MODEL	DESCRIPTION
MDLS5	Electronic card input signal, range 6 to 9, 4 to 7, 8 to 11, 1 to 5 V d.c., 4 to 20 mA for MDL32/34/36
MDLV5	Electronic card input signal, range 0 to 10 V d.c., 4 to 20 mA with adjustable start point and span for MDL32/34/36
DMDL	Two auxiliary microswitches SPDT 10 (3) A - 240 V a.c. adjustable on the whole stroke for MDL
MDLA1	Damper drive linkage for MDL
MDLA2	Linkage for mounting MDL when replacing SL
MDLPA2	Board with 1 K Ohm auxiliary potentiometer for MDL2
MDLPA4	Board with 1 K Ohm auxiliary potentiometer for MDL4
MDLPA6	Board with 1 K Ohm auxiliary potentiometer for MDL6
YS7	Crank-arm in addition to MDLA1 composed of 2 joints and 8-mm rod for dampers with 10 to 18mm shaft with MDL actuator
DMDA	Two auxiliary microswitches for MDA

Without Spring Return **MDB** Series. For air dampers up to 4 m². IP54.

MODEL	CONTROL SIGNAL	TORQUE [Nm]	POWER SUPPLY	AUX MICRO SWITCH	MAX DAMPER SURFACE [m ²]	TIMING [s. for 90°]
MDB42	2-3 pos.	5	24 Vac/dc	-	1	60..120
MDB42M				2	1	60..120
MDB52	2...10 V			-	1	60..120
MDB24	2-3 pos.	10	85-265 Vac	-	2	< 150
MDB24M				1	2	< 150
MDB44			-	2	< 150	
MDB44M			1	2	< 150	
MDB54	2...10 V			-	2	< 150
MDB26	2-3 pos.	15	85-265 Vac	-	3	< 150
MDB26M				1	3	60..120
MDB46			-	3	< 150	
MDB46M			1	3	60..120	
MDB56	2...10 V			-	3	< 150
MDB28	2-3 pos.	20	85-265 Vac	-	4	< 150
MDB28M				2	4	< 150
MDB48			-	4	< 150	
MDB48M			2	4	< 150	
MDB58			2...10 V	-	4	< 150



With Electronic Return **MDS** series. For air dampers up to 4 m². IP54.

MODEL	CONTROL SIGNAL	TORQUE [Nm]	POWER SUPPLY	AUX MICRO SWITCH	MAX DAMPER SURFACE [m ²]	TIMING [s. for 90°]
MDS206R	2 pos.	6	230 Vac	-	1,5	60...80
MDS206RM			230 Vac	1	1,5	60...80
MDS406R			24 Vac/dc	-	1,5	60...80
MDS406RM			24 Vac/dc	1	1,5	60...80
MDS506R	0...10 V		24 Vac/dc	-	1,5	60...80
MDS506RM		24 Vac/dc	1	1,5	60...80	
MDS210R	2 pos.	10	230 Vac	-	2	60...80
MDS210RM			230 Vac	1	2	60...80
MDS410R			24 Vac/dc	-	2	60...80
MDS410RM			24 Vac/dc	1	2	60...80
MDS510R	0...10 V		24 Vac/dc	-	2	60...80
MDS510RM		24 Vac/dc	1	2	60...80	
MDS220R	2 pos.	20	230 Vac	-	4	90...125
MDS220RM			230 Vac	2	4	90...125
MDS420R			24 Vac/dc	-	4	90...125
MDS420RM			24 Vac/dc	2	4	90...125
MDS5205R	0...10 V		24 Vac/dc	-	4	90...125
MDS520RM		24 Vac/dc	2	4	90...125	



For a proper valve selection we need to define:

- Hydraulic circuit: constant flow (3-way) or variable flow (2-way)
- Max Hydraulic pressure for the circuit -- > PN
- Maximum and minimum fluid temperature
- Fluid type (e.g. water, water+glycol, steam, thermal oil, ...)
- Valve function: on/off control, linear flow control or EQM flow control.

Once we have identified the type of valve, we need to select its size and the actuator that will motorize it.

To select the correct type and size of valve the following factors need to be taken into consideration:

- Max working pressure to select the proper PN
- Max temperature and type of fluid
- Max differential pressure achievable by the valve/actuator assembly
- Pressure drop as a consequence of the flow rate
- Flow characteristic, Rangeability, Authority

Each valve is identified by its FLOW COEFFICIENT called Kvs. Kvs, in metric system, represents the flow in m³/h of water (specific weight=1) at the temperature of 15.5°C which causes a pressure drop of 1Kg/cm² (1 bar) when the valve is fully open.

In the USA flow coefficient is called Cv where $Kvs = 0.865 Cv$
The value of Kvs represents the valve size: -- > **control valves size needs to be chosen according to the calculated Kvs and not according to the pipe size.**

In any case, valve size must not be larger than pipe size.

For calculating the Kvs, we need to know: flow rate and differential pressure. Differential pressure can be selected equal to the pressure drop in the heat exchanger.

Kvs can be calculated:

- using the appropriate formulas available on page 58 for water or steam;
- using the diagrams on pages 56 and 57;
- using our dedicated software for PC (available online).

Each type of valve is subject to a max pressure value = nominal working pressure, indicated by PN (Kg/cm²) depending on valve raw material.

The max differential pressure value represents the max differential pressure between inlet and outlet of the valve, when the valve is fully closed.

This value depends on both the actuator power, which must provide full opening and full closing, and on the mechanical-structural limitations of the valve, as construction type and valve body material, stem and plug type and material, stem packing, etc.

After having selected the necessary Kvs value, we should select the size of the valve matching a Kvs value as close as possible to the calculated Kvs.

The identified valve size can achieve several values of max. differential pressure according to the actuator.

Max. differential values are listed in columns in the previous pages of this book.

The actuator needs to be selected in terms of force as to:

- guarantee the effective differential pressure across the valve in case of a 3way valve;
- guarantee the effective differential pressure across the valve and the maximum pressure, at the inlet port of the valve, available from the pump, in case of 2way valves. Consequently 2way valves usually require actuators stronger than those necessary for 3way valves.

As a consequence of the differential pressure across the valve the flow is always trying to open the valve.

To keep the plug in the closed position the actuator must exceed this force (close-off pressure).

Depending on the valve size and on the differential pressure across the valve we need to select an actuator with a close-off higher than the differential pressure.

The larger is the valve the more is the force that the actuator needs to have to achieve the close-off.

For 2-way valves with high differential pressure we recommend using our pressure balanced plug valves 2TGA.B (from 3/4" to 2" -- > page 21) and 2FGB.B, 2FSA.B, 2FAA.B, 2FGA200B (from DN65 to 200 -- > page 26).

This is a cost effective alternative to selecting a standard valve with a strong actuator.

Complete details of differential pressure values for all our valves are listed in our data sheet Valves_DBL337E.pdf available online on our web site

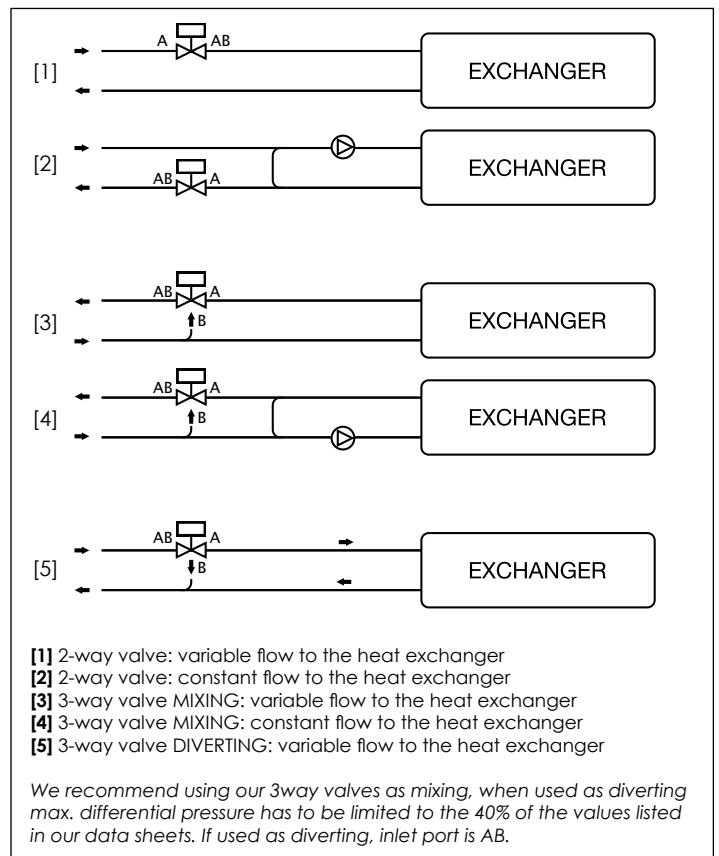



ACTUATORS

VALVES

		MVT		MVC		MVX		MCA	
PNI 6 BRASS VALVES									
VSXT	2 way	MVT503S	MVC203 MVC403	MVC503R	MVX22R MVX42R	MVX52	MCA230L(M) MCA24L(M)	2 pos. 24V; 230V	
VMXT	3 way	prop. 24V	3 pos. 24V; 230V	prop. 24V	prop. 24V	prop. 24V	140 N	140 N	
VXT	3 way + bypass	300 N	300 N	300 N	140 N	140 N	140 N	140 N	
PNI 6 BRASS VALVES									
VSX	2 way	•	-	•	•	-	•	• NORMALLY OPEN	
VMX	3 way	•	-	•	•	-	•	• NORMALLY OPEN	
VTX	3 way + bypass	•	-	•	•	-	•	• NORMALLY OPEN	
PNI 6 CAST IRON VALVES									
VSBT.-VMBT.	2 and 3 way	•	-	•	-	-	-	• NORMALLY OPEN	
VSBI.-VMBI.	2 and 3 way	-	•	•	-	-	-	• NORMALLY OPEN	
2TGA.B	2 way	•	-	•	-	-	-	• NORMALLY OPEN	
2TGA.BT	2 way	-	•	•	-	-	-	• NORMALLY OPEN	
2-3TGB.B	2 and 3 way	-	with AG74-03	with AG74-03	with AG74-03	-	-	• NORMALLY OPEN	
PNI 6 BRONZE VALVES									
2-3TBB.T	2 and 3 way	-	•	•	-	-	-	•	

ACTUATORS

VALVES

		MVR		MVX		MVT		MVC		MVE	
PICV's											
VIX	2 way	MVR24C2 MVR230C2	MVX52B	MVT203S MVT403S	MVC503R	MVE204S MVE504S	MVE215 MVE515	3 pos. & prop. 24V; 230V			
VSXT09PBP VSXT10PBP	2 way	2 pos. 24V; 230V	prop. 24V	3 pos. 24V; 230V	prop. 24V	prop. 24V	prop. 24V	prop. 24V	prop. 24V	prop. 24V	prop. 24V
BV65P BV80P	2 way	90 N	140 N	300 N	300 N	400 N	1000 N	1500 N	1500 N		
BY100P BV125P	2 way	•	•	•	•	•	•	•	•		

* ATTENTION: MVX52B without power closes VSX. VMX and VTX valves
 ** ATTENTION: MVX52B without power opens VLX valves



VALVES

		MDA		MDL	
BUTTERFLY VALVES PNI 6					
VFA	Butterfly valves	MDA2. MDA4.	MDA5.	MDL4	MDL6
		2 - 3 pos. 24V; 230V	prop. 24V	3 pos. & prop. 24V; 230V	
		20-40 Nm	20 Nm	30 Nm	
		•	•	with AF24	with AF25

ACTUATORS

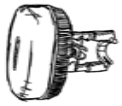

VALVES

		MVB		MVE		MVER (with emergency return)		MVH		
MVB22	MVB52	MVE.04	MVE.04S	MVE.04R	MVE.04SR	MVH36	MVH56E	MVH56EA		
MVB26	MVB56	MVE.06	MVE.06S	MVE.06R	MVE.06SR	MVH56	MVHE3K	MVH56EC		
MVB28		MVE.10	MVE.10S	MVE.10R	MVE.10SR					
MVB46		MVE.15	MVE.15S	MVE.15R	MVE.15SR					
2 - 3 pos. 24V; 230V	prop. 24V	3 pos. & prop. 24V; 230V	3 pos. & prop. 24V; 230V short yoke	3 pos. & prop. 24V; 230V	3 pos. & prop. 24V; 230V short yoke	prop. pot. or Vdc-mA 24V	3 pos. & prop. 24V	3 pos. & prop. 24V spring return		
450 N		400 N, 1500 N, 2200 N	400 N, 600 N, 1000 N, 1500 N	400 N, 600 N, 1000 N, 1500 N	400 N, 600 N, 1000 N, 1500 N	1500 N	1500 N	700 N		
PN16 THREADED VALVES										
2-3TGB.B	2 and 3 way threaded									
2-3TGB.F	2 and 3 way threaded									
VS	2 way threaded									
V	3 way threaded									
VSBP. M	2 way threaded tight close-off									
VMBP. M	3 way threaded tight close-off									
2-3TBB	2 and 3 way bronze									
PN16 FLANGED VALVES										
VS	2 way slip-on flanges									
V	3 way slip-on flanges									
PN16, 25, 40 FLANGED VALVES										
2FGB	2 way flanged PN16									
3FGB	3 way flanged PN16									
2FGA	2 way flanged PN16									
2FSA **	2 way flanged PN25									
3FSA **	3 way flanged PN25									
2FAA **	2 way flanged PN40									
3FAA **	3 way flanged PN40									
FLANGED VALVES FOR HIGH CLOSE-OFF PRESSURE										
2FGB.B	2 way flanged PN16									
2FSA.B	2 way flanged PN25									
2FAA.B	2 way flanged PN40									
2FAA150B	2 way double seat PN25									
2FGA200B	2 way double seat PN16									
2-3FA	2 and 3 way flanged PN16 - PN40									

* Available on request

** Also 2FAA.P, 2FAA.T, 3FAA.P, 3FAA.T, 3FSA.S

COMPATIBLE VALVES / LINKAGE KITS

MANUFACTURER	MODEL	WAY	TYPE	MVE	MVH	MVH56EA/C
SCHNEIDER ELECTRIC	V241	2way	threaded	compatible	compatible	compatible
	V211T	2way	threaded	compatible	compatible	compatible
	V212T	2way	threaded	compatible	compatible	compatible
	V211	2way	flanged	compatible	compatible	compatible
	V212	2way	flanged	compatible	compatible	compatible
	VG211	2way	flanged	compatible	compatible	compatible
	VG222	2way	flanged	compatible	compatible	compatible
	V231	2way	flanged	compatible	compatible	compatible
	V232	2way	flanged	compatible	compatible	compatible
	V292	2way	flanged	compatible	compatible	compatible
	V341	3way	threaded	compatible	compatible	compatible
	V311T	3way	threaded	compatible	compatible	compatible
	V311	3way	flanged	compatible	compatible	compatible
	VG321	3way	flanged	compatible	compatible	compatible
V321	3way	flanged	compatible	compatible	compatible	
SATCHWELL	VZ	2way	threaded	AG53	AG54	AG54
	VSF DN15-50	2way	flanged	AG53	AG54	AG54
	VZF DN65 150	2way	flanged	AG53	AG54	AG54
	MZ	3way	threaded	AG53	AG54	AG54
	MJF DN15-50	3way	flanged	AG53	AG54	AG54
	MZF DN 65-150	3way	flanged	AG53	AG54	AG54
HONEYWELL	V176A,B	2way	flanged	AG60-10	X	X
	V5011A	2way	flanged	AG60-10	X	X
	V5011R	2way	threaded	AG79	X	X
SIEMENS	VVF21 DN 25..80	2way	flanged	AG70-10	AG70-10	AG70-10
	VVF21DN ≥100	2way	flanged	AG70-14	AG70-14	AG70-14
	VVF31 DN 15..80	2way	flanged	AG70-10	AG70-10	AG70-10
	VVF31DN 150	2way	flanged	AG70-14	AG70-14	AG70-14
	VVF40 DN 15..80	2way	flanged	AG70-10	AG70-10	AG70-10
	VVF40 DN 150	2way	flanged	AG70-14	AG70-14	AG70-14
	VVF41 DN 50	2way	flanged	AG70-14	AG70-14	AG70-14
	VVF41 DN 65..150	2way	flanged	AG70-14	AG70-14	AG70-14
	VVF45 DN 50	2way	flanged	AG70-14	AG70-14	AG70-14
	VVF45 DN65..150	2way	flanged	AG70-14	AG70-14	AG70-14
	VVF51DN15..40	2way	flanged	AG70-10	AG70-10	AG70-10
	VVF52 DN 15..40	2way	flanged	AG70-10	AG70-10	AG70-10
	VVF53 DN 15..50	2way	flanged	AG70-10	AG70-10	AG70-10
	VVF53 DN 65..150	2way	flanged	AG70-10	AG70-10	AG70-10
	VVF61 DN 15..25	2way	flanged	AG70-10	AG70-10	AG70-10
	VVF61 DN 40..50	2way	flanged	AG70-14	AG70-14	AG70-14
	VVF61 DN 65..150	2way	flanged	AG70-14	AG70-14	AG70-14
	VVF61_2 DN 15..50	2way	flanged	AG70-10	AG70-10	AG70-10
	VVF61_2 DN 65..150	2way	flanged	AG70-10	AG70-10	AG70-10
	VVG41 DN 15.50	2way	threaded	AG70-10	AG70-10	AG70-10
VVG11 DN 25..40	2way	threaded	AG70-10	AG70-10	AG70-10	
VXF21DN 25..80	3way	flanged	AG70-10	AG70-10	AG70-10	

MANUFACTURER	MODEL	WAY	TYPE	MVE	MVH	MVH56EA/C
SIEMENS	VXF21DN 100	3way	flanged	AG70-14	AG70-14	AG70-14
	VXF31 DN 15..80	3way	flanged	AG70-10	AG70-10	AG70-10
	VXF31 DN 100..150	3way	flanged	AG70-14	AG70-14	AG70-14
	VXF40 DN 15..80	3way	flanged	AG70-10	AG70-10	AG70-10
	VXF40 DN 100..150	3way	flanged	AG70-14	AG70-14	AG70-14
	VXF41 DN 50	3way	flanged	AG70-14	AG70-14	AG70-14
	VXF41 DN 65..150	3way	flanged	AG70-14	AG70-14	AG70-14
	VXF45 DN 50	3way	flanged	AG70-14	AG70-14	AG70-14
	VXF45 DN 65..150	3way	flanged	AG70-14	AG70-14	AG70-14
	VXF51 DN 15..40	3way	flanged	AG70-10	AG70-10	AG70-10
	VXF52 DN 15..40	3way	flanged	AG70-10	AG70-10	AG70-10
	VXF53 DN 15..50	3way	flanged	AG70-10	AG70-10	AG70-10
	VXF53 DN 65..150	3way	flanged	AG70-10	AG70-10	AG70-10
	VXF61 DN 15..25	3way	flanged	AG70-10	AG70-10	AG70-10
	VXF61 DN 40..50	3way	flanged	AG70-14	AG70-14	AG70-14
	VXF61 DN 65..150	3way	flanged	AG70-14	AG70-14	AG70-14
	VXF61_2 DN 15..50	3way	flanged	AG70-10	AG70-10	AG70-10
	VXF61_2 DN 65..150	3way	flanged	AG70-10	AG70-10	AG70-10
	VXG41 DN 15..50	3way	threaded	AG70-10	AG70-10	AG70-10
	VXG11 DN 25..40	3way	threaded	AG70-10	AG70-10	AG70-10
BELIMO	H6..N DN 15..100	2 way	flanged	AG70-10	X	X
	H7..N DN 15..100	3 way	flanged	AG70-10	X	X
	H2...X-S	2 way	threaded	AG82	X	X
	H3...X-S	3 way	threaded	AG82	X	X
JOHNSON CONTROLS	VB7816	3way	threaded	AG66	X	X
DANFOSS	VF2	2way	flanged	AG60-07	X	X
	VF3	3way	flanged	AG60-07	X	X
MUT	MK DN50 - 150	3way	flanged	AG69	X	X

x = link not available



2F & 3F VALVES CROSS REFERENCE WITH OLD CONTROLLI VALVES

	OLD MODEL	NEW MODEL	
	2 WAY VALVES PN40		
Steel valves	SSAA15R	2FAA15R2	
	SSAA15	2FAA15	
	SSAA20	2FAA20	
	SSAA25	2FAA25	
	SSAA32	2FAA32	
	SSAA40	2FAA40	
	SSAA50	2FAA50	
	SSAA65	2FAA65	
SSAA80	2FAA80		
Steel valves for very high temperatures	SSAACP15R	2FAA15PR2	
	SSAACP15	2FAA15P	
	SSAACP20	2FAA20P	
	SSAACP25	2FAA25P	
	SSAACP32	2FAA32P	
	SSAACP40	2FAA40P	
	SSAACP50	2FAA50P	
	SSAACP65	2FAA65P	
SSAACP80	2FAA80P		
Steel valves for very low temperatures	SSAACP15RB	2FAA15TR2	
	SSAACP15B	2FAA15T	
	SSAACP20B	2FAA20T	
	SSAACP25B	2FAA25T	
	SSAACP32B	2FAA32T	
	SSAACP40B	2FAA40T	
	SSAACP50B	2FAA50T	
	SSAACP65B	2FAA65T	
SSAACP80B	2FAA80T		
Balanced plug valves	VBAA25	2FAA25B	
	VBAA32	2FAA32B	
	VBAA40	2FAA40B	
	VBAA50	2FAA50B	
	VBAA65	2FAA65B	
	VBAA80	2FAA80B	
3 WAY VALVES PN25	VMS25R	3FSA25R4	
	VMS25I	3FSA25R7	
	VMS25	3FSA25	
	VMS32	3FSA32	
	VMS40	3FSA40	
	VMS50	3FSA50	
Spheroidal cast iron valves	VMS65	3FSA65	
	3VSA80	3FSA80	
	High temperature valves	VMSTS25R	3FSA25SR4
		VMSTS25I	3FSA25SR7
		VMSTS25	3FSA25S
		VMSTS32	3FSA32S
VMSTS40		3FSA40S	
VMSTS50		3FSA50S	
VMSTS65		3FSA65S	
3VSATS80		3FSA80S	

	OLD MODEL	NEW MODEL	
	2 WAY VALVES PN16		
Cast iron valves with s/steel internal parts	SSGA11	2FGA15R0	
	SSGA12	2FGA15R1	
	SSGA15R	2FGA15R2	
	SSGA1	2FGA15R3	
	SSGA15	2FGA15	
	SSGA20	2FGA20	
	SSGA25	2FGA25	
	SSGA32	2FGA32	
	SSGA40	2FGA40	
	SSGA50	2FGA50	
Cast iron valves	SSGA65	2FGA65	
	SSGA80	2FGA80	
	SSGA100	2FGA100	
	VSG25R	2FGB25R4	
	VSG25I	2FGB25R7	
	VSG25	2FGB25	
	VSG40	2FGB40	
	VSG50	2FGB50	
	VSG65	2FGB65	
	VSG80	2FGB80	
Balanced plug valves	VSG100	2FGB100	
	VSG125	2FGB125	
	VSG150	2FGB150	
	VBG65	2FGB65B	
	VBG80	2FGB80B	
	VBG100	2FGB100B	
3 WAY VALVES PN16	VBG125	2FGB125B	
	VBG150	2FGB150B	
	DSGA200	2FGA200B	
	Cast iron valves	VMB1625R	3FGB25R4
		VMB1625I	3FGB25R7
		VMB1625	3FGB25
VMB1640R		3FGB40R19	
VMB1640		3FGB40	
VMB1650		3FGB50	
VMB1665		3FGB65	
VMB1680		3FGB80	
VMB16100		3FGB100	
VMB16125		3FGB125	
VMB16150	3FGB150		

	OLD MODEL	NEW MODEL
	2 WAY VALVES PN25	
Spheroidal cast iron valves	VSS25R	2FSA25R4
	VSS25I	2FSA25R7
	VSS25	2FSA25
	VSS32	2FSA32
	VSS40	2FSA40
	VSS50	2FSA50
Balanced plug valves	VSS65	2FSA65
	VBS25R	2FSA25BR4
	VBS25I	2FSA25BR7
	VBS25	2FSA25B
	VBS32	2FSA32B
	VBS40	2FSA40B
	VBS50	2FSA50B
	VBS65	2FSA65B
Steel valves	VBS80	2FSA80B
	DSAA150	2FAA150B
	3 WAY VALVES PN40	
	3VAA25R	3FAA25R4
	3VAA25I	3FAA25R7
	3VAA25	3FAA25
	3VAA32	3FAA32
	3VAA40	3FAA40
	3VAA50	3FAA50
	3VAA65	3FAA65
Steel valves for very high temperatures	3VAA80	3FAA80
	3VAA100	3FAA100
	3VAA125	3FAA125
	3VAACP25R	3FAA25PR4
	3VAACP25I	3FAA25PR7
	3VAACP25	3FAA25P
	3VAACP32	3FAA32P
	3VAACP40	3FAA40P
	3VAACP50	3FAA50P
	3VAACP65	3FAA65P
Steel valves for very low temperatures	3VAACP80	3FAA80P
	3VAACP100	3FAA100P
	3VAACP125	3FAA125P
	3VAACP25RB	3FAA25TR4
	3VAACP25IB	3FAA25TR7
	3VAACP25B	3FAA25T
	3VAACP32B	3FAA32T
	3VAACP40B	3FAA40T
3VAACP50B	3FAA50T	
3VAACP65B	3FAA65T	
3VAACP80B	3FAA80T	
3VAACPI00B	3FAA100T	
3VAACPI25B	3FAA125T	

OLD MODEL	NEW MODEL	
MVL-SH ACTUATORS	MVH-MVE ACTUATORS	DESCRIPTION
245	248	Stem heater for MVH-MVE with flanged valves
245F		
246	244	Stem heater for MVH-MVE with VSB-VMB-VSBF-VMBF valves
AG31	AG62	Linkage for MVH actuators with VSB-VMB-VSBF-VMBF valves
DMVL	DMVH	Aux. microswitches for MVH
MVLF55	MVHF55	4-20 mA input signal
MVLP2	MVHP2	1kOhm aux. potentiometer for MVH26
MVLP4	MVHP4	1kOhm aux. potentiometer for MVH46
MVLHT	MVHT	High temperature spacer

REPLACING OLD CONTROLLI ACTUATORS

In the event of replacing an old Controlli actuator mounted on one of the old valves listed below, here is the equivalent MVH and MVE actuators model to be used:

OLD MODEL		NEW MODEL	
SH242	=	MVH26	+ AG51 or AG62 valve/actuator linkage kit (see LINKAGE KITS chart below)
SH222		MVH46	
SH522		MVH56	
MVL26		MVH26	
MVL36		MVH36	
MVL46		MVH46	
MVL56		MVH56	
MVL56F		MVH56E	
MVL56A / MVL56FA/MVL46A		MVH56EA	
MVL56C / MVL56FC/MVL46C		MVH56EC	
MVL3K	=	MVHE3K	no linkage kit required
MVF54		MVE506	
MVF58		MVE510	
MVF515		MVE515	
MVF54S		MVE506S	
MVF58S		MVE510S	
MVF515S		MVE515S	
MVH56F		MVH56E	
MVH56FA		MVH56EA	
MVH56FC		MVH56EC	
MVH3K	=	MVHE3K	no linkage kit required
MVT28		MVT203S	
MVT44		MVT403S	
MVT56		MVT503S	
MVT56S		MVT503S	
MVT57		MVT503S	
MVT56L	=	MVT503S	+ 55061 kit
MVT203		MVC203	
MVT403		MVC403	
MVT503		MVC503	

LINKAGE KITS FOR MVH, MVE & MVB ACTUATORS

CONTROLLI VALVES MODELS	MVH	MVE	MVB
OBSOLETE MODELS			
S300	x	x	AG40
V500	x	x	AG22
OLD FLANGED VALVES			
VSG, VMB16, VBG, SS, DS, VSS, VBS, VBAA, 3V, VMS	AG51		x
SS, DS, VS, VBS, 3V, VM + MVLHT DN15÷65mm	AG64	x	x
SS, DS, VS, VBS, 3V, VM + MVLHT DN80÷200mm	AG65	x	x
EXISTING THREADED VALVES			
2TGB.B, 3TGB.B	x	x	compatible
2TGB.F, 3TGB.F	x	compatible	x
VSB, VMB	AG62	AG52 / AG63 *	compatible
EXISTING VALVES WITH SLIP-ON FLANGES			
VSB.F, VMB.F	AG62	AG52 / AG63 *	compatible
EXISTING FLANGED VALVES			
2F, 3F	compatible	compatible	x

*AG52 (MVE) & AG63 (MVE.S)

Valve Sizing Diagram for Fluids

$$Kvs = \frac{Q \cdot 10}{\sqrt{\Delta p v}}$$

Q = flow rate in m³/h
 Δpv = pressure drop in kPa

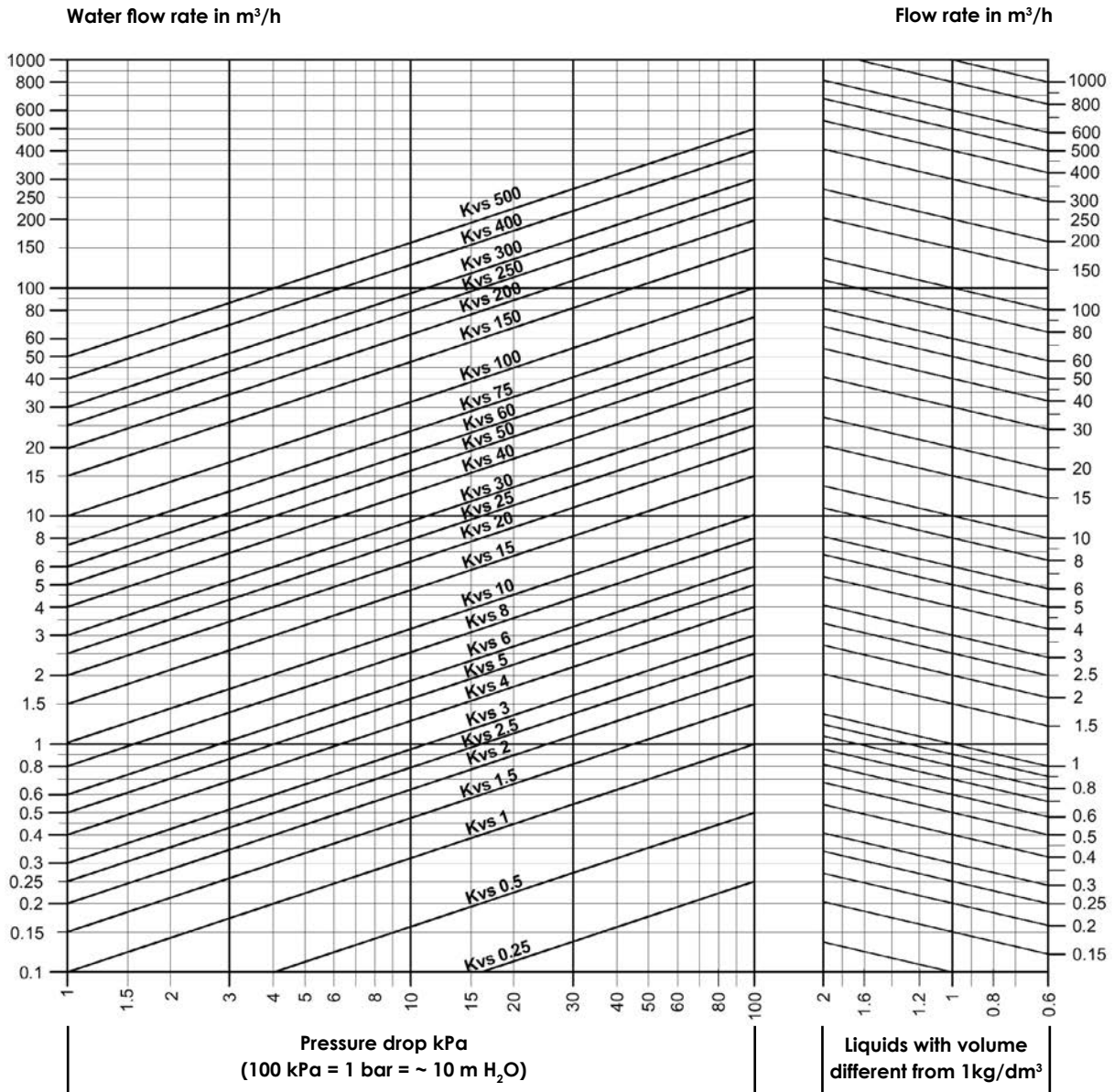

The recommended valve pressure drop must be at least equal to the load.

Example for fluids with relative density 1 kg/dm³ (water)

In order to size a control valve with:

FLOW RATE: 7,5 m³/h of water

PRESSURE DROP: 55 kPa

Use the diagram as follows:

- Identify the crossing point between the line starting from the flow rate value (7,5 m³/h) and from the pressure drop value (55 kPa). This point corresponds to the required flow coefficient, i.e. Kvs 10. Therefore, the control valve must have Kvs 10.

Example for liquids having relative density different from 1 kg/dm³

In order to size a control valve with:

FLOW RATE : 150 m³/h having (0,9 kg/dm³) relative density

PRESSURE DROP: 80 kPa

Use the diagram as follows:

Identify the crossing point (right side of the diagram) between the line starting from the relative density value (0,9 kg/dm³) and the inclined line starting from the flow rate value (150 m³/h).

Identify the crossing point between the line starting from the crossing point above and the other from the pressure drop value (80 kPa).

This point corresponds to the required flow coefficient. Therefore, the control valve must have approximately kvs 160.

Example with diathermic oil.

It could be convenient to size the valve on diathermic oil using the water diagram. To do this, it is necessary to apply the following conversion formula, which takes into account the mass and the "average" specific heat of diathermic oil:

$$Q = \frac{K \text{ calories}}{\Delta t 500} \text{ in m}^3/\text{h} = \text{water}$$

Valve Sizing Diagram for Steam

$$Kvs = \frac{Q}{22.8 \cdot \sqrt{\Delta p_v \cdot P_u}}$$

Saturated steam flow rate kg/h

Overheated steam flow rate kg/h

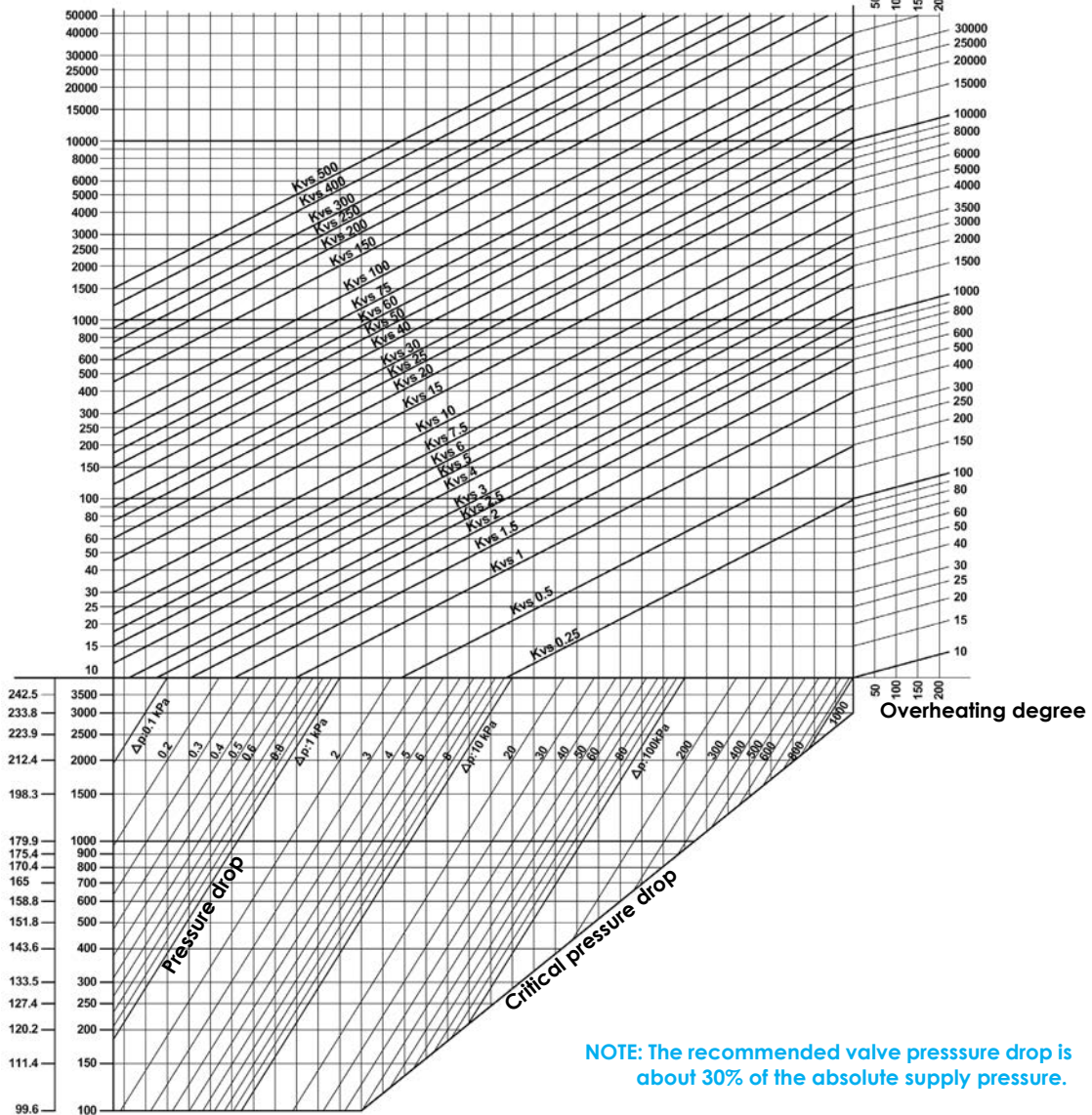

NOTE: The recommended valve pressure drop is about 30% of the absolute supply pressure.

Example for saturated steam:

FLOW RATE: 4700 Kg/h of saturated steam
 ABSOLUTE PRESSURE UPSTREAM: 850 kPa
 PRESSURE DROP: 160 kPa

Use the diagram as follows:

- Identify the crossing point between the line starting from absolute pressure upstream the valve (850 kPa) and the inclined line corresponding to the pressure drop value (160 kPa).
- Identify the crossing point between the line starting from the crossing point above and the line from the flow rate value (4700 Kg/h). This point corresponds to the required flow rate coefficient: Kvs 63.

Example for overheated steam:

FLOW RATE: 140 Kg/h of overheated steam
 ABSOLUTE PRESSURE UPSTREAM: 350 kPa
 TEMPERATURE: 209 °C
 PRESSURE DROP: 100 kPa

Calculate the overheating degree of steam as follows:

- On the left side of the diagram, read the temperature value corresponding to 350 kPa (139 °C). The overheating degree is: 209 – 139 = 70 °C

Use the diagram as follows:

- Identify the crossing point "A" (right side of the diagram) between the line starting from the overheating value (70 °C) and the inclined line corresponding to the flow rate value (140 Kg/h).
- Identify the crossing point "B" between the line starting from the value of pressure upstream (350 kPa) and the inclined line corresponding to the value of pressure drop (100 kPa).
- Identify the crossing point between the line starting from the points "A" and "B".

How to Calculate Kvs

Flow coefficient Kvs is the flow rate of water in m³/h passing through a fully open valve at a 100 kPa pressure drop.

$$\text{a) Liquids } kvs = 10 \times Q \times \sqrt{\frac{r}{Dp}}$$

Q = flow rate m³/h

Dp = pressure drop (kPa)

r = relative density

The Dp pressure drop should be determined as follows:

- Equal or higher than the Dp of the circuit under control, in case of variable flow applications
- Equal or higher than the Dp of the supply circuit, in case of constant flow applications

$$\text{b) Steam } kvs = \frac{100 \times G \times C}{20.3 \sqrt{P_2 \times Dpv}}$$

G = flow rate (kg/h)

C = 1 + 0.0013 (t-ts)

t = steam temperature in working conditions

ts = saturated steam temperature at P₂ pressure

P₂ = pressure downstream (kPa)

Dpv = pressure drop (kPa)

Choose the valve with the Kvs closest to the calculated one.

Water Systems

Two-way valve

For this application the pressure drop through the valve must be high, in order to have a good control flow characteristic and a properly working system.

- 1) The valve pressure drop must be 30 to 50% of the pressure upstream the valve.
- 2) The valve pressure drop must be equal to, or higher than the pressure drop of the coil or heat exchanger under control, in particular:

TEMPERATURE DROP OF HEAT EXCHANGER

DESIGN OF VALVE PRESSURE DROP

30 °C

Equal to pressure drop of heat exchanger

20 °C

Twice as pressure drop of heat exchanger

10 °C

Three times as pressure drop of heat exchanger

Three-way mixing valve

For mixing valve a high pressure drop is not normally required even when used in primary and secondary water circuits to control supply temperature to users.

As a general rule, the valve must have a pressure drop similar to the one of the heat exchanger.

Three-way diverting valve

Three-way diverting valves are used to control flow to heat exchanger and, therefore, the pressure drop through the valve. For proportional systems it must be high.

Note:

When selecting pressure drop, you must not exceed the above-mentioned values because an undersized valve could produce:

- Noisy operation and vibration of the plug
- Rapid wear of plug and seat due to high speed of the fluid through the valve.

Overheated Water Systems

For this application the valves can be two- or three-way type.

The valve pressure drop must be high, in order to have a good control flow characteristic and a properly working system.

The principles and rules for correct sizing are the same as "WATER SYSTEMS".

Steam Systems

For low pressure steam systems (up to 2 kPa), the pressure drop through the valve must be from 60 to 80 % of the pressure available upstream the valve.

STEAM PRESSURE UPSTREAM THE VALVE

VALVE PRESSURE DROP

0.5 bar (50 kPa)

40 kPa

1.0 bar (100 kPa)

70 kPa

For high pressure steam systems (above 2 bar) the pressure drop through the valve must be from 30 to 40% of the pressure available upstream the valve.

STEAM PRESSURE UPSTREAM THE VALVE

VALVE PRESSURE DROP

200 kPa

80 kPa

600 kPa

200 kPa

1,000 kPa

300 kPa

For on/off valves there are no particular rules to follow: pressure drop may be 10 to 20% of inlet pressure, but the valve is normally pipe sized.

Note:

Do not size valves for high pressure steam with pressure drop higher than 50% of absolute pressure upstream: beyond this percentage thermodynamic problems could affect valve efficiency and life.

Heat Transfer Oil Systems

The most commonly used valve type is three-way with linear characteristics, in order to ensure a constant flow to the boiler by constant speed.

Two-way valves can be used for several low-power users and wherever a balanced-plug valve is mounted between supply and return boiler.

The pressure drop of three-way valves must be at least equal to or higher than the one of the heat exchanger.

For a single user control, the valve must have a pressure drop from 30 to 50% of the system pressure drop.

For two-way valves, see also the "WATER SYSTEMS" section.

Controlli S.p.A.

Via Carlo Levi 52,
16010 Sant'Olcese (Genova)
ITALY

Tel +39 010 73 06 229

Tel +39 010 73 06 208

Tel +39 010 73 06 296

export@controlli.eu

www.controlli.eu

Our distributor:

